

# Installation, Operation and Maintenance Manual



## Oil Fired Warm Air Furnace

### LHO Series Lowboy

THE INSTALLATION OF THIS FURNACE SHALL BE IN ACCORDANCE WITH THE REGULATION OF AUTHORITIES HAVING JURISDICTION AND NFPA STANDARD 31 (U.S.A.) OR CSA STANDARD B139 (CAN.).

FOR YOUR SAFETY  
Do not store or use gasoline or other flammable vapors or liquids in the vicinity of this or any other appliance.

Oneida Royal Division  
Utica, New York

Please read this manual completely before beginning installation. These instructions must be kept with the furnace for future reference.



How to read an Oneida Royal Model Number:

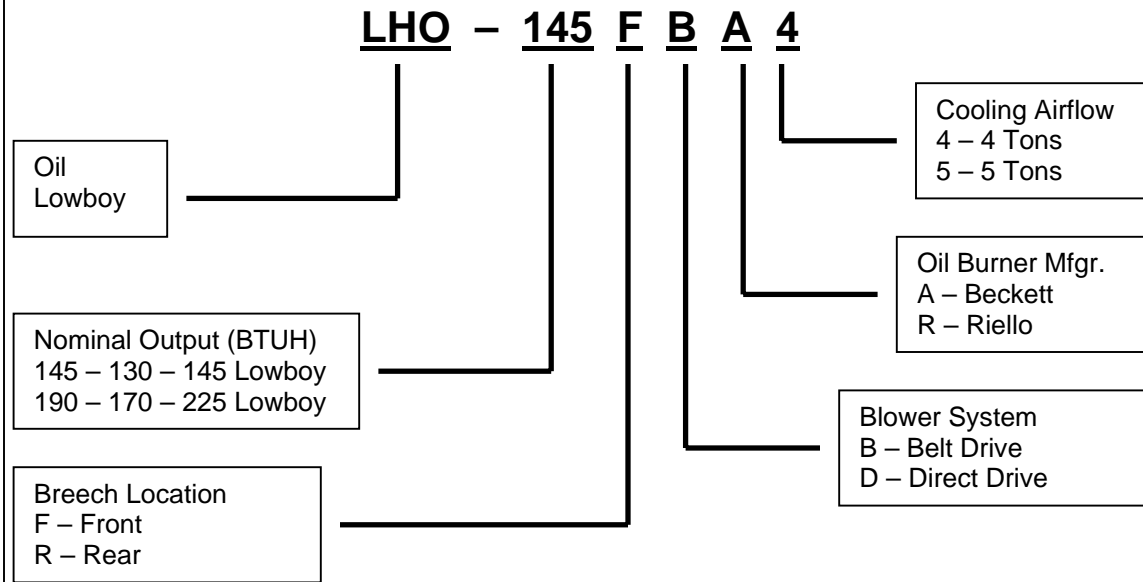

In the above example, the furnace is an Oneida Royal Lowboy, front breeched, belt drive, Beckett Oil Burner, 4 tons of cooling.

In this Installation, Operation & Maintenance Manual, the models will be abbreviated as 145F and 145R for front breech and rear breech 130 to 145 MBH standard models, and 190R for rear breech, two-piece, high capacity models.

# Table of Contents

1. Introduction.....	4
2. Heat Loss.....	4
3. Location of Unit .....	4
4. Air Conditioning Applications.....	5
5. Combustion Air.....	5
6. Chimney Venting .....	5
7. Barometric Damper Control .....	7
8. Furnace Controls.....	7
9. Electrical Connections.....	8
10. Humidifier .....	9
11. Oil Tank.....	9
12. Piping Installation.....	9
13. Oil Filter .....	10
14. Oil Burner Nozzles.....	10
15. Combustion Chamber .....	10
16. Burner Electrodes .....	10
17. Oil Burner Set Up.....	10
18. Circulating Air Blower.....	12
19. Maintenance and Service.....	13
20. Furnace Installation Set Up .....	14
21. Operating Instructions .....	15
Table A-1 Beckett AF Oil Burner Set-Up .....	16
Table A-2 Riello 40F Oil Burner Set-Up .....	16
Table A-3 Direct Drive Blower Set-Up .....	17
Table A-4 BELT Drive Blower Set-Up .....	17
General Dimensions: LHO-145 Models .....	20
General Dimensions: LHO-190 Models .....	21
Wiring Diagram: .....	22
R7184 Detailed Sequence of Operation .....	23
R7184 LED Diagnostic Light.....	27
Table C-1: Cad Cell Resistance.....	27
Table C-2: R7184 Troubleshooting .....	28
Table C-3: System and General Troubleshooting .....	32
Parts List .....	36

**IMPORTANT:**  
**SAVE THESE INSTRUCTIONS FOR FUTURE REFERENCE**

## 1. INTRODUCTION

Please read these instructions completely and carefully before installing and operating the furnace.

The furnace must be installed and set up by a qualified contractor

### 145F and 145R STANDARD MODELS

The standard lowboy models are available in both front breech and rear breech configurations. Both configurations may be fired at 1.10 US GPH or 1.20 US GPH (No. 2 furnace oil), and produce outputs of 130,000 or 143,000 BTUH. Both rear breech and front breech models are available with direct drive or belt drive blower assemblies, with airflow capacities to handle up to five tons of air conditioning. Both front and rear breech models feature Beckett oil burners with PSC motors, CleanCut<sup>®</sup> oil pumps, electronic igniters, and R7184B oil primary controls. The standard models feature cabinet heights of 41 inches. Throughout this manual, these standard models will be referred to as 145F and 145R models.

### 190R HIGH CAPACITY MODELS

The high capacity lowboy models are available in a rear breech configuration only. All feature Beckett AF burners. The LHO-190RBA4 may be fired between 1.50 US GPH and 1.65 US GPH (No. 2 furnace oil), and produce outputs of 168,000 to 188,000 BTUH. The LHO-190RBA5 may be fired at the 1.50 and 1.65 US GPH rates as well as between 1.75 US GPH and 2.00 US GPH (No. 2 furnace oil), and produce outputs of 196,000 to 224,000 BTUH. Both models are available with belt drive blower assemblies only. The LHO-190RBA4 has an airflow capacity sufficient to handle up to four tons of air conditioning. The LHO-190RBA5 has an airflow capacity sufficient to handle up to five tons of air conditioning. Throughout this manual, these models will be referred to as 190R models.

All furnace models are listed with the **Canadian Standards Association, (CSA)**, complies with both United States and Canadian standards for use with No. 1 (Stove) and No. 2 (Furnace) Oil. Please refer to the tables in the appendix for performance and dimensional data.

## **⚠ WARNING**

**DO NOT USE GASOLINE, CRANK CASE OIL, OR ANY OIL CONTAINING GASOLINE.**

In the United States of America, the installation of the furnace and related equipment shall be installed in accordance with the regulations of **NFPA No. 31, Installation of Oil Burning Equipment**, as well as in accordance with local codes.

In Canada, the installation of the furnace and related equipment shall be installed in accordance with the regulations of **CAN/CSA - B139, Installation Code For Oil Burning Equipment**, as well as in accordance with local codes.

When installation or application questions arise, local regulations generally take precedence over the National Codes. Regulations prescribed in the National Codes and the general instructions provided with this installation manual. When in doubt, please consult your local authorities.

All models are shipped assembled and pre-wired. The furnace should be carefully inspected for damage when being unpacked.

## 2. HEAT LOSS

To determine the correct furnace and firing rate for an application, it is necessary to calculate the maximum hourly heat loss of the building based on local design conditions. In new construction, the heat loss should be calculated on a room-by-room basis to enable proper sizing of the trunk and branch ducts. In retrofit applications, a building shell (overall) heat loss calculation may be used.

In the United States, **Manual J**, titled, "**Load Calculation**" published by the **Air Conditioning Contractors of America**, describes a suitable procedure for calculating the maximum hourly heat loss.

In Canada, the maximum hourly heat loss may be calculated in accordance with the procedures described in the manuals of the **Heating, Refrigeration and Air Conditioning Institute of Canada (HRAI)**, or by other method prescribed by authorities having jurisdiction that are suitable for local conditions.

## 3. LOCATION OF UNIT

The furnace should be located such that the flue connection to the chimney is short, direct and consists of as few elbows as possible. When possible, the unit should be centralized with respect to the supply and return air ductwork. A central location minimizes the trunk duct sizing. All models may be installed on wood floors. Do not install the furnace on carpet or tiled floors.

Minimum installation clearances are listed in Table 1.

**TABLE 1: CLEARANCE TO COMBUSTIBLES**

Top	3 in. <sup>1</sup>
Bottom	0 in.
Rear	24 in.
Side 1	6 in. <sup>2</sup>
Side 2	18 in. <sup>2</sup>
Front	24 in.
Flue Pipe	18 in. <sup>3</sup>
Enclosure	Standard
<sup>1</sup> Includes plenum top. <sup>2</sup> 18 in. required on one side as service access to rear. <sup>3</sup> 9 in. in Canada.	

#### 4. AIR CONDITIONING APPLICATIONS

If the furnace is used in conjunction with air conditioning, the furnace shall be installed in parallel with or upstream from the evaporator coil to avoid condensation in the heat exchanger. In a parallel installation, the dampers or air controlling means must prevent chilled air from entering the furnace. If the dampers are manually operated, there must be a means of control to prevent the operation of either system unless the dampers are in the full heat or full cool position. The air heated by the furnace shall not pass through a refrigeration unit unless the unit is specifically approved for such service.

The blower speed must be checked and adjusted to compensate for the pressure drop caused by the evaporator coil. Refer to Appendix B for recommended wiring and electrical connections of the air conditioning controls.

#### 5. COMBUSTION AIR

When a furnace is installed in the full basement of a typical frame or brick house, infiltration is normally adequate to provide air for combustion and draft operation. If the furnace is installed in an enclosed utility room, (confined space), two (2) ventilation openings must be provided connecting to a well ventilated space (full basement, living room or other room opening thereto, but not a bedroom or bathroom). One opening shall be located near the top and the bottom of the enclosure near the front of the furnace. For furnaces located in buildings of unusually tight construction, such as those with high quality weather stripping, caulking, windows and doors, or storm sashed windows, or where basement windows are well sealed, a permanent opening communicating with a well ventilated attic or with the outdoors shall be provided, using a duct if necessary. Size all of the openings and associated ductwork by the standards provided in the latest Oil

Installation Code editions; NFPA 31 in the United States, CAN/CSA B139 in Canada. Take all fuel burning appliances in the area into consideration when calculating combustion and ventilation air requirements.

#### General Guidelines:

For furnaces located in confined space adjacent to well-ventilated areas, the openings must have a free area based on 1 in.<sup>2</sup> per 1000 BTU/Hr.

For furnaces located in confined space receiving both combustion air and ventilation air ducted in from outdoors, the openings must have a free area based on 1 in.<sup>2</sup> per 4000 BTU/Hr. for vertical ducts, or 1 in.<sup>2</sup> per 2000 BTU/Hr. for horizontal ducts.

Vertical ducts may conduct air from well-ventilated attics or crawl spaces. Horizontal ducts must have outdoor terminations located where they will not be blocked by debris or snow.

For furnaces located in confined space receiving combustion air from outdoors and ventilation air from the indoors (confined space), two openings, one near the top, the other near the bottom must still be used. The openings must be sized on the basis of 1 in.<sup>2</sup> per 1000 BTU/Hr. if taking the air from an adjacent room. In addition, an opening that communicates freely with the outdoors must be provided. The openings must have a free area based on 1 in.<sup>2</sup> per 5000 BTU/Hr. (1 in.<sup>2</sup> per 4000 BTU/Hr. in Canada).

The Model CAS-2B-90E Furnace Boot manufactured by Field Controls, Inc. may be used with the furnace to obtain combustion air directly from outdoors. Use of this device does not alter the need for ventilation air; however, it does provide a good direct source of combustion air and is connected directly to the oil burner.

#### 6. CHIMNEY VENTING

The chimney must be sized correctly and be in good repair. If the chimney is oversized, there is a high risk of the flue gases condensing resulting in damage to the chimney and other venting parts. This problem may be corrected by the use of an appropriately sized chimney liner.

If the chimney serves the 145F or 145R furnace only, the vent will be typically sized at 4-inch minimum, 6-inch maximum. If the chimney serves the 190R furnace only, the vent will typically be sized at 6-inch minimum, 8-inch maximum. The data provided in Table 3 is based on dedicated venting. If the furnace is to be co-vented with other appliances, refer to **NFPA 211**, *Standard for Chimneys, Fireplaces, Vents, and Solid Fuel-Burning Appliances*, **NFPA 31**, *Standard for the Installation of Oil*

Burning Equipment or CAN/CSA B139, Installation Code For Oil Burning Equipment for correct sizing information.

**Figure 1: Common Chimney Problems**

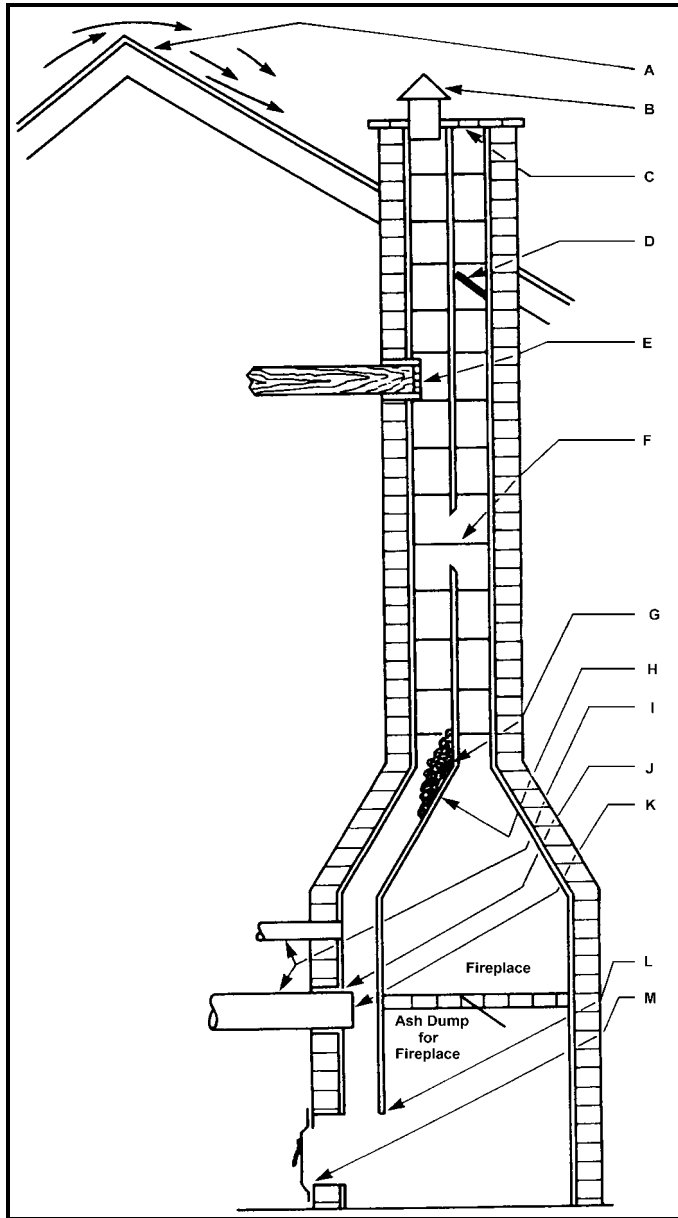

**Table 2: Common Chimney Problems**

Refer to Figure 1			
Key	Trouble	Diagnostic	Remedy
A	Top of chimney lower than surrounding objects	Observation	Extend chimney above all surrounding objects within 30 feet.
B	Chimney Cap or ventilator.	Observation	Remove
C	Coping restricts	Observation	Make opening

	opening.		as large as inside of chimney.
Key	Trouble	Diagnostic	Remedy
D	Obstruction in chimney	Can be found by light and mirror reflecting conditions in chimney.	Use weight to break and dislodge.
E	Joist protruding into chimney.	Lowering a light on an extension cord.	Must be handled by competent masonry contractor.
F	Break in chimney lining.	Smoke test - build smudge fire blocking off other opening, watching for smoke to escape.	Must be handled by competent masonry contractor.
G	Collection of soot at narrow space in flue opening.	Lower light on extension cord.	Clean out with weighted brush or bag of loose gravel on end of line.
H	Offset	Lower light on extension cord.	Change to straight or to long offset.
I	Two or more openings to the same chimney.	Found by inspection from basement.	The least important opening must be closed, using some other chimney flue.
J	Loose-seated pipe in flue opening.	Smoke test.	Leaks should be eliminated by cementing all pipe openings.
K	Smoke pipe extends into chimney.	Measurement of pipe from within or observation of pipe by means of a lowered light.	Length of pipe must be reduced to allow end of pipe to be flush with inside of tile.
L	Failure to extend the length of flue partition to the floor.	By inspection or smoke test.	Extend partition to floor level.
M	Loose-fitted clean-out door.	Smoke test.	Close all leaks with cement.

**NOTE: This furnace is approved for use with L-Vent.**

**NOTE: Maximum temperature for L-Vent is 575°F (300°C).**

**Table 3: Min. Chimney Base Temperatures (°F)**

Model & Output (,000)	Chimney Height (ft.)			
	11	20	28	36
Chimneys with Thermal Resistance less than R6				
145F/R 130	245	300	365	430
145F/R 143	240	275	320	365
190R 168	240	275	320	365
190R 188	240	275	320	365
190R 196	230	265	295	330
190R 224	230	265	295	330
Model & Output (,000)	Chimney Height (ft.)			
	11	20	28	36
Chimneys with Thermal Resistance greater than R6				
145F/R 130	165	180	190	200
145F/R 143	165	180	185	195
190R 168	165	175	185	195
190R 188	165	175	185	195
190R 196	165	175	175	185
190R 224	165	175	175	185

Figures based on (-4°F) outdoor temperatures. If extremely cold outdoor temperature conditions exist, higher base temperatures may be necessary. Local experience may also justify higher chimney base temperatures.

**IMPORTANT:** The chimney must be capable of providing sufficient draft at all times for the safe removal of the products of combustion.

The chimney should be tested under “winter” conditions; doors and windows closed, all other fossil fuel burning appliances on, clothes dryer on, bathroom fans on, etc. If the chimney cannot overcome the competition for air, it will be necessary to access the reason for it, and take corrective action. If the chimney is found to be correctly sized and in good repair, it will be necessary to re-evaluate the source availability of combustion and ventilation air, and take corrective action.

The flue pipe should be as short as possible with horizontal pipes sloping upward toward the chimney at a rate of one-quarter inch to the foot. The flue pipe should not be smaller in cross sectional area than the flue collar on the furnace. The flue pipe should connect to the chimney such that the flue pipe extends into, and terminates flush with the inside surface of the chimney liner. Seal the joint between the pipe and the lining. The

chimney outlet should be at least two feet above the highest point of a peaked roof. All unused chimney openings should be closed. Chimneys must conform to local, provincial or state codes, or in the absence of local regulations, to the requirements of the National Building Code.

See Figure 1 and Table 2 for common chimney problems and their remedies.

**⚠ CAUTION**

**THE FURNACE MUST BE CONNECTED TO A FLUE HAVING SUFFICIENT DRAFT AT ALL TIMES TO ENSURE SAFE AND PROPER OPERATION OF THE APPLIANCE.**

The flue pipe must not be routed through concealed space, because it must be visually checked for signs of deterioration during the annual inspection and servicing. The flue pipe must not pass through any floor or ceiling, but may pass through a wall where suitable fire protection provisions have been installed. In the United States, refer to the latest edition of NFPA 31 for regulations governing the installation of oil burning equipment. In Canada, refer to the latest edition of CAN/CSA B139 for rules governing the installation of oil burning equipment.

### 7. BAROMETRIC DAMPER CONTROL

This device is used in conjunction with conventional chimney venting. This control (or draft regulator) automatically maintains a constant negative pressure in the furnace to obtain maximum efficiency. It ensures that proper pressures are not exceeded. If the chimney does not develop sufficient draft, the draft control cannot function properly. The draft regulator, must be installed within the same room or enclosure as the furnace, and should not interfere with the combustion air supplied to the burner. The control should be located a minimum of 3 flue pipe diameters from the furnace breeching and installed in accordance to the instructions supplied with the regulator.

### 8. FURNACE CONTROLS

All furnace combustion functions are controlled by the R7184B Oil Primary Control. The oil primary control utilizes a standard C554A cad cell type flame detector. The oil primary control controls the built-in oil solenoid valve in the oil pump.

The oil burner circuit is protected by a cartridge type 15-ampere fuse.

High limit protection is provided by the L6064A combination fan/limit control.

The circulating fan is controlled by the L6064A combination fan/limit control on all models.

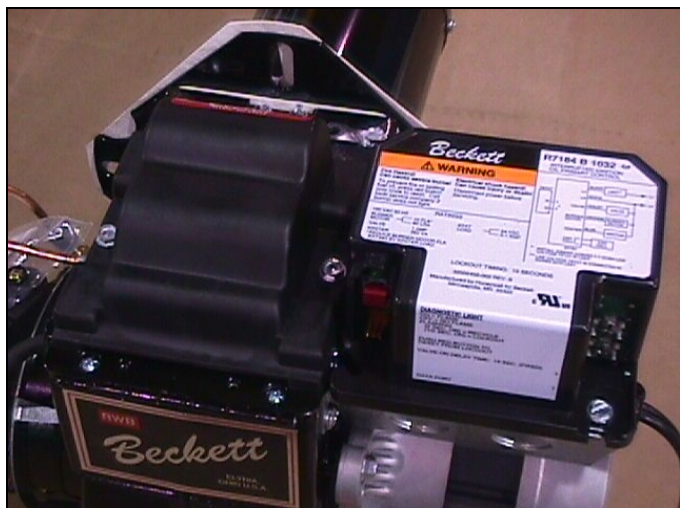

**Figure 2:** R7184B Oil Primary Control

All furnaces supplied with direct drive blower systems are equipped with a fan center control. These models are air conditioning ready; no additional furnace controls are necessary to provide the 24vac control circuit for the air conditioning contactor and for fan switching.

Certain furnace models equipped with direct drive blower systems include a switch located in the furnace vestibule for continuous low speed fan operation.



**Figure 3:** Fan Center and Low Speed Switch

All models equipped with belt drive blower systems are shipped as heating only models. If air conditioning is added, it will be necessary to field install a fan center.

## 9. ELECTRICAL CONNECTIONS

The furnace is listed by the **Canadian Standards Association (CSA)**. It is factory wired and requires minimal field wiring. In the United States, the wiring must be in accordance with the **National Fire Protection Association NFPA-70, National Electrical Code**, and with local codes and regulations. In Canada, all field wiring should conform to **CAN/CSA C22.1 Canadian Electrical Code, Part 1**, and by local codes, where they prevail.

The furnace should be wired to a separate and dedicated circuit in the main electrical panel; however, accessory equipment such as electronic air cleaners and humidifiers may be included on the furnace circuit. Although a suitably located circuit breaker can be used as a service switch, a separate service switch is advisable. The service switch is necessary if reaching the circuit breaker involves becoming close to the furnace, or if the furnace is located between the circuit breaker and the means of entry to the furnace room. The furnace switch (service switch) should be clearly marked, installed in an easily accessible area between the furnace and furnace room entry, and be located in such a manner to reduce the likelihood that it would be mistaken as a light switch or similar device.

The power requirements for all 4 ton models (1/2 hp or 3/4 hp blower systems): 115 VAC, 1  $\emptyset$ , 60 Hz., 15A.

The power requirements for all 4 ton models (1/2 hp or 3/4 hp blower systems): 115 VAC, 1  $\emptyset$ , 60 Hz., 20A.

Accessories requiring 120 VAC power sources such as electronic air cleaners and humidifier transformers may be powered from the furnace circuit. Do not use the direct drive motor connections as a power source, since there is a high risk of damaging the accessories by exposure to high voltage from the auto-generating windings of the direct drive motor.

Thermostat wiring connections and air conditioning contactor low voltage connections are shown in the wiring diagrams. Some micro-electronic thermostats require additional controls and wiring. Refer to the thermostat manufacturer's instructions.

The thermostat should be located approximately 5 feet above the floor, on an inside wall where there is good natural air circulation, and where the thermostat will be exposed to average room temperatures. Avoid locations where the thermostat will be exposed to cold drafts, heat from nearby lamps and appliances, exposure to sunlight, heat from inside wall stacks, etc.

Normal heat anticipator setting: 0.1 A. For more precise adjustment, the heat anticipator may be adjusted to the amperage draw of the heating control circuit as measured between the "R" and "W" terminals of the



thermostat. To reduce the risk of damaging the heat anticipator, do not measure circuit without first removing one of the two wires first. To determine the heating circuit amperage draw:

1. Disconnect one of the “R” or “W” wires from the thermostat terminal.
2. Connect an ammeter between the wire and the thermostat terminal to which it was attached.
3. Note the amperage reading when the heating contacts are closed. (System switch must be on “HEAT” if so equipped).
4. Re-connect the thermostat wire. If the thermostat is serving a combination heating and air conditioning system, pay particular attention to polarity.
5. When the thermostat is reconnected and re-plumbed, adjust the heat anticipator setting to match the observed amperage reading.

## 10. HUMIDIFIER

A humidifier is an optional accessory available through most heating supplies outlets. Installation should be carried out in accordance with the humidifier manufacturer's installation instructions. Water or water droplets from the humidifier should not be allowed to come into contact with the furnace heat exchanger. Do not use direct drive motor connections as a source of power for 120 VAC humidifiers and humidifier transformers.

## 11. OIL TANK

Oil storage tanks must be selected and installed in compliance with applicable codes; in the United States, **NFPA 31, *Standard for the Installation of Oil Burning Equipment***, Chapter 2. and in Canada, **CAN/CSA-B139, *Installation Code for Oil Burning Equipment***, Section 6. Observe all local codes and by-laws.

In general, the oil tank must be properly supported and remain stable in both empty and full condition. The oil tank must be fitted with vent and supply pipes to the outdoors. Refer to the above-mentioned codes for sizing. The vent pipe must be no less than 1¼ inches I.P.S., and terminate with an appropriate vent cap in a location where it will not be blocked. The fill pipe must be no less than 2 inches I.P.S., and terminate with an appropriate cap in a location where debris will not enter the fill pipe during oil delivery.

If located indoors, the tank should normally be in the lowest level, (cellar, basement, etc.). It must be equipped with a shut-off valve at the tank outlet used for the oil supply. The oil tank must be located as to not block the furnace / room exit pathway. Observe all clearances specified in the above-mentioned codes.

## 12. PIPING INSTALLATION

In the United States, **NFPA 31, *Standard for the Installation of Oil Burning Equipment***, Chapter 2.

In Canada, the entire fuel system should be installed in accordance with the requirements of CAN/CSA B139, and local regulations. Use only approved fuel oil tanks piping, fittings and oil filters.

Ensure that all fittings used in a copper oil line system are high quality flare fittings. Do not use compression fittings.

Do not use Teflon tape on any fittings.

Pressurized or gravity feed installations must not exceed 3 PSIG. Pressures greater than 10 PSIG may cause damage to the shaft seal. If the height of the oil stored in a tank above the oil burner exceeds 11½ feet, it may be necessary to use a pressure-regulating device approved for this purpose.

The furnace may be installed with a one-pipe system with gravity feed or lift. The maximum allowable lift on a single line system is 8 feet. Lift should be measured from the bottom (outlet) of the tank, to the inlet of the burner. Sizing a single line system is complex because of the difficulty estimating the pressure drop through each fitting, bend and component in the line. In general, keep single line systems short as possible. 2-stage oil pumps are not available for Beckett burner with the CleanCut® oil pump. The following chart shows the allowable line lengths (horizontal + vertical) for single and two stage oil pumps. All distances are in feet.

In retrofit applications, where an existing oil line system is in place, a vacuum check will help determine the efficacy of the existing oil line system. The vacuum developed should not exceed 6” Hg. for a single pipe system, nor 12” Hg. for a two-pipe system.

**Table 4: Oil Lines**

Copper Tubing Oil Line Lengths (Feet)				
Lift (feet)	Single-Pipe		Two-Pipe	
	1½" O.D. Tubing	2" O.D. Tubing	1½" O.D. Tubing	2" O.D. Tubing
0	53	100	68	100
1	49	100	65	100
2	45	100	63	100
3	41	100	60	100
4	37	100	58	100
5	33	100	55	100
6	29	100	53	100
7	25	99	50	100
8	21	83	48	100
9	17	68	45	100
10	13	52	42	100
12	---	---	37	100

14	---	---	32	100
16	---	---	27	100
18	---	---	22	88

For additional information, see the installation information sheet included in the documents envelope or affixed to the oil burner.

**NOTE:** Both the oil burner requires the use of a bypass plug when converting from single-pipe to two-pipe oil piping systems. See burner manufacturer's instructions.

### 13. OIL FILTER

All fuel systems should include an oil filter between the fuel oil storage tank and the oil burner. For best results, install the oil filter as close to the burner as possible. When using an indoor oil tank, the oil filter may be installed at the tank downstream from the shut-off valve.

### 14. OIL BURNER NOZZLES

The 145F and 145R lowboy furnaces are certified for multiple firing rates, ranging from 130,000 to 143,000 BTU/hr, while the 190R lowboy furnaces are certified for multiple firing rates ranging from 168,000 to 188,000 BTU/hr., or with the 5 ton blower system, up to 224,000 BTU/hr. By changing the oil burner nozzle within the specific Model Range, and temperature rise, the furnace may be fired at an ideal rate for a wide range of structures.

**Table 5: Nozzles (Beckett Oil Burner)**

MODEL Input (MBH)	NOZZLE		
	DELAVAN	HAGO	STIENEN
145F/R (130)	1.10/70°A	1.10/70°H	1.10/70°H
145F/R (143)	1.20/60°A	1.20/60°H	1.20/60°H
190R (168)	1.50/70°B	1.50/70°B	1.50/70°S
190R (188)	1.65/70°B	1.65/70°B	1.65/70°S
190R (196)	1.75/70°B	1.75/70°B	1.75/70°S
190R (224)	2.00/70°B	2.00/70°B	2.00/70°S

### 15. COMBUSTION CHAMBER

This furnace is equipped with an efficient cerafelt combustion chamber. It is held in place by a retaining bracket.

**CHECK THE ALIGNMENT OF THE COMBUSTION CHAMBER AND OIL BURNER BEFORE FIRING. IT IS POSSIBLE FOR THE COMBUSTION CHAMBER TO SHIFT IF SUBJECTED TO ROUGH HANDLING DURING TRANSIT.**

The cerafelt combustion chamber is quite soft initially. After firing, it becomes very brittle. Be sure to do all alignment and positioning adjustments before the first firing.

The combustion chamber should be inspected for damage or carbon build up whenever the oil burner is removed for repairs or routine maintenance.



**BEFORE OPERATING THE FURNACE CHECK BURNER ALIGNMENT WITH COMBUSTION CHAMBER. THE END CONE OF THE AIR TUBE MUST BE CENTRED TO THE ACCOMODATING RING PROVIDED IN THE DESIGN OF THE COMBUSTION CHAMBER. ADJUST ALIGNMENT AS NECESSARY BEFORE FIRST FIRING.**

### 16. BURNER ELECTRODES

Correct positioning of the electrode tips with respect to each other, to the fuel oil nozzle, and to the rest of the burners is essential for smooth light ups and proper operation.

Beckett Oil Burner:

The electrode tips should be adjusted to a gap of 5/32", 1/16" ahead of the nozzle, 5/16" above the centerline of the nozzle. The "Z" dimension (front edge of the burner head to the front face of the nozzle is 1-1/8 inches.

The electrode porcelains should be free of cracks, the electrode tips should be tapered and free of burrs, and the contact rods must be clean and be in firm contact with the ignition transformer contact springs. The electrodes must not come into contact with the burner head.

### 17. OIL BURNER SET UP

The burner air supply is adjusted to maintain the *fuel to air ratio* to obtain ideal combustion conditions. A lack of air causes "soft" and "sooty" flames, resulting in soot build-up throughout the heat exchanger passages. Excess combustion air causes a bright roaring fire and high stack temperatures resulting in poor fuel efficiency.

#### PREPARATIONS:

Drill a 1/4" test port in the venting, ideally at least 2 flue pipe diameters away from the furnace breeching, if venting horizontally from the furnace, or from the flue pipe elbow if venting vertically before reaching the furnace. (see Figures 5 and 6).

The test port will allow flue gas samples to be taken and stack temperatures to be measured.

Before starting the burner, check the burner alignment with the combustion chamber (fire pot), check that the correct nozzle is tightened into place, and that the burner electrodes are properly positioned. The Beckett burner bulk air band is should be closed, and the air shutter initial setting should be approximately 7.00.

Refer to Table A-2, page 18, for Riello oil burner air damper and turbulator settings.

**PROCEDURE:**

Start the burner and allow it to run at least ten minutes. Set the air shutter to give a good flame visually. On Beckett burners, the combustion air supply to the burner is controlled by manipulating the air shutter on the left side of the burner, and, if necessary, the bulk air band. To adjust, loosen the bolt on the movable shutter. Move the shutter gradually until a good flame (visually) has been achieved. Re-slug the bolt.

Refer to the Riello Oil Burner Manual for setting the air adjustment plate.

Check the oil pump pressure. Refer to Table A1, page 17, for pump pressure settings.

After reaching steady state, take a smoke test. If not indicating a trace, set the combustion air controls to provide a trace.

Check the initial draft setting as the furnace warms up. The draft may be measured over-fire or at the breech. A draft reading of -0.02 inches w.c. measured at the breech will provide sufficient over-fire draft.

Typically, the CO<sub>2</sub> reading will range between 11.5% to 13.5%.

After the air adjustments have been completed, and the air shutter or air adjustment plate has been secured, re-check the draft and take another smoke test to ensure that the values have not changed.

NOTE: Riello Oil Burners - When taking final test readings, be sure that the burner cover is in place.

**Figure 4: Test port location for smoke test horizontal.**

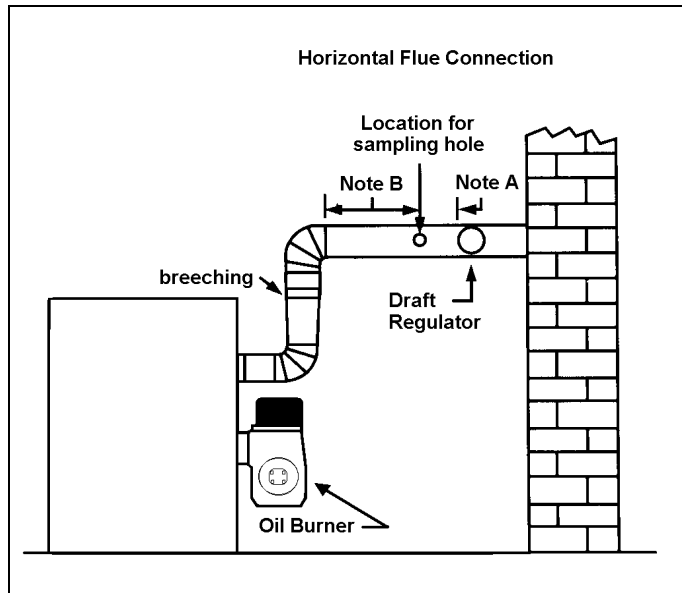

Courtesy of R. W. Beckett Corporation.

**Figure 5: Test port location for smoke test vertical.**

Courtesy of R. W. Beckett Corporation

**Note A:** Locate hole at least 6 inches on the furnace side of the draft control.

**Note B:** Ideally, hole should be at least 12 inches from breeching or elbow.

**SMOKE TEST NOTE:**

If oily or yellow smoke spots are found on the smoke test filter paper, it is usually a sign of unburned fuel. This indicates poor combustion. This type of problem may be caused by excess draft, excess air, or contaminated fuel. Do not ignore this indicator.

**STACK TEMPERATURE:**

Stack temperature will vary depending on fuel input, circulating air blower speed, and burner set up, etc. In general, stack temperature should typically range between 380°F to 550°F, assuming that the combustion air is approximately room temperature (65°F - 70°F). In general, lower stack temperature indicates greater efficiency; however, excessively low stack temperature can lead to condensation forming in the chimney and / or venting. Sulphur and similar contaminants in the fuel oil will mix with condensation to form acids. Acids and resultant chemical salts will cause rapid deterioration of the chimney and venting components, and may attack

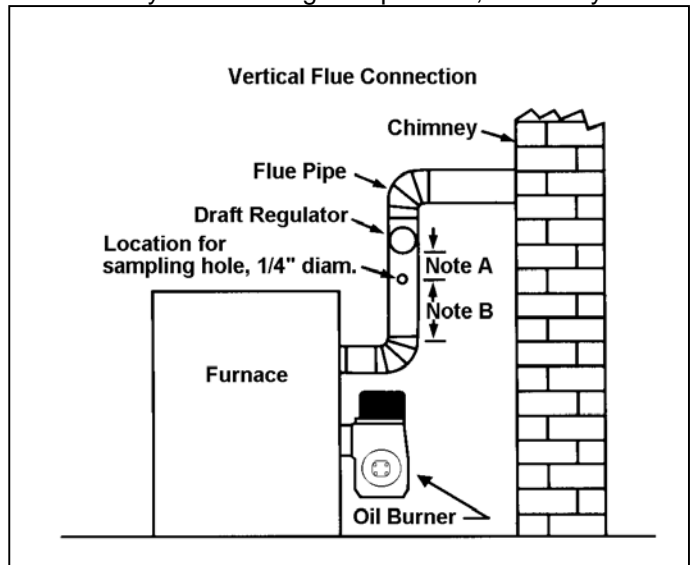

the furnace.

If the flue gases are below the range, it may be necessary to slow down the blower fan. If the flue gases are above the range, the blower fan may require speeding up. Stack temperature varies directly with the system temperature rise. System temperature rise is the difference between the furnace outlet temperature and furnace inlet temperature as measured in the vicinity of the connection between the plenum take-offs and the trunk ducts. Typical temperature rise values range between 70°F and 85°F.

If the venting from the furnace to the chimney is long, or exposed to cold ambient temperatures, it may be necessary to use L-Vent as the vent connector to reduce stack temperature loss to prevent condensation. The venting should be inspected annually to ensure that it is intact.

## **! WARNING**

**IF THE FURNACE FAILS TO IGNITE, CHECK THE OIL TANK FUEL GAUGE. IF THE FUEL GAUGE SHOWS THAT OIL IS PRESENT, PRESS THE RESET BUTTON ONCE ONLY. IF THE BURNER FAILS TO IGNITE, CONTACT YOUR SERVICE CONTRACTOR.**

## **! CAUTION**

**ALL FURNACE CONTROLS ARE SENSITIVE AND SHOULD NOT BE SUBJECTED TO TAMPERING. IF PROBLEMS PERSIST, CALL YOUR SERVICE CONTRACTOR.**

## **18. CIRCULATING AIR BLOWER**

### **DIRECT DRIVE**

Both the 145F and 145R lowboy furnaces may be equipped with a direct drive blower system. Direct drive blower speed adjustments are not normally required in properly sized extended plenum duct systems. The motor RPM and air CFM delivery will vary automatically to accommodate conditions within the usual range of external static pressures typical of residential duct systems. Under-sized duct systems may require a higher blower speed to obtain a reasonable system temperature rise. Some older duct systems were not designed to provide static pressure. They typically feature special reducing fittings at each branch run and lack block ends on the trunk ducts. These systems may be better suited to belt drive blower systems. If a direct drive blower

system is selected, modifications may be required to provide some resistance to the airflow to prevent over-amping of the direct drive blower motor. Selecting a lower blower speed may correct this problem.

Direct drive blower speeds are adjusted by changing the "hot" wires to the motor winding connections. Please refer to wiring diagram in Appendix B or the wiring diagram label affixed to the furnace. **THE NEUTRAL WIRE (normally the white wire) IS NEVER MOVED TO ADJUST THE BLOWER SPEED.**

## **! CAUTION**

**DO NOT CONNECT POWER LEADS BETWEEN MOTOR SPEEDS. THE NEUTRAL WIRE MUST ALWAYS BE CONNECTED TO THE MOTOR'S DESIGNATED NEUTRAL TERMINAL.**

It is possible and acceptable to use a single blower speed for both heating and cooling modes. The simplest method to connect the wiring from both modes is to use a "piggy-back connector" accommodating both wires on a single motor tap. It is also acceptable to connect the selected motor speed with a pigtail joined to both heating and cooling speed wires with a wire nut. As a safety precaution against accidental disconnection of the wires by vibration, it is advisable to secure the wire nut and wires with a few wraps of electricians tape.

If the joining of the blower speed wiring is done in the furnace junction box, tape off both ends of the unused wire.

### **BELT DRIVE**

All lowboy furnaces may be equipped with a belt drive blower assembly. Belt drive blower systems can be modified for a variety of speeds and air delivery by adjusting the variable speed motor pulley, and / or by changing the blower pulley.

The variable speed motor pulley may be adjusted by loosening the 5/32 Allen set screw in the outer sheave, and turning the outer sheave clockwise to increase blower speed; counter clockwise to reduce blower speed. Ensure that the setscrew is tightened at one of the "flat spots", failure to do so will convert the variable speed pulley to a fixed speed pulley by ruining the threads. The blower speed can also be modified by changing the blower pulley. A smaller blower pulley will cause the blower to turn faster; a larger pulley will reduce blower speed. Large increases in blower speed will increase power requirements. Check the amperage draw of the blower motor after changes have been made. If the amperage draw is greater than the value listed on the motor rating plate, replace with a motor with a higher horsepower rating.

The fan belt tension is very important. There should be a deflection of between  $\frac{3}{4}$  of an inch to 1 inch. Less deflection places a strain on the blower bearings, and increases start up amperage draw. More deflection allows excess slippage and causes premature motor pulley wear. Automotive belt dressings are not recommended. A hard soap such as Sunlight® soap will work well as a belt dressing, for the purpose of reducing belt squeaks, etc. If used, the soap should be applied to the sides of the belt only.

Other than remembering to arrange for the annual professional servicing of the furnace by the service or installation contractor, the most important routine service performed by the homeowner is to maintain the air filter or filters. A dirty filter can cause the furnace to over-heat, fail to maintain indoor temperature during cold weather, increase fuel consumption and cause component failure. The furnace filter(s) should be inspected, cleaned or replaced monthly. The furnace is factory equipped with a semi-permanent type filter. If the filter is damaged, replace with filters of the same size and type.

**⚠ WARNING**

**THE BELT DRIVE COMPONENTS OPERATE AT HIGH SPEEDS AND CAN EASILY SNAG LOOSE CLOTHING, CAUSING SERIOUS PERSONAL INJURY. THIS PROCEDURE SHOULD BE LEFT TO TRAINED SERVICE PERSONNEL.**

During the routine service, inspect the general condition of the furnace watching for signs of oil leaks in the vicinity of the oil burner, soot forming on any external part of the furnace, soot forming around the joints in the vent pipe, etc. If any of these conditions are present, please advise your service or installation contractor.

If the blower RPM operates above 1000 RPM, it is advisable to replace the sintered bronze blower bearings with ball bearing type blower bearings.

**⚠ CAUTION**

**DISCONNECT THE POWER SUPPLY TO THE FURNACE BEFORE OPENING THE BLOWER ACCESS DOOR TO SERVICE THE AIR FILTER, FAN AND MOTOR. FAILURE TO SHUT OFF POWER COULD ALLOW THE BLOWER TO START UNEXPECTEDLY, CREATING A RISK OF DEATH OR PERSONAL INJURY.**

Do not use the blower speed wires as a source of power to accessories as electronic air cleaners and humidifier transformers. The unused motor taps auto-generate sufficiently high voltages to damage accessory equipment.

**⚠ CAUTION**

**DO NOT START THE BURNER OR BLOWER FAN UNLESS THE BLOWER ACCESS DOOR IS SECURELY IN PLACE.**

## 19. MAINTENANCE AND SERVICE

### A: Routine Maintenance By Home Owner

## B: Annual Service By Contractor



The heat exchanger should be inspected periodically and cleaned if necessary. If cleaning is necessary, **SHUT OFF POWER TO THE FURNACE** and remove the burner. Using a stiff brush with a wire handle, brush off scale and soot from inside the drum and flue pipe. To clean the radiator, remove the round cover or covers on the inner radiator access pipes located on the front panel between the oil burner and the flue pipe.

A wire brush can be used to loosen dirt and debris on the inside surfaces of the radiator. Clean out all accumulated dirt, soot and debris with a wire handled brush and an industrial vacuum cleaner. Replace the clean-out covers.

Most circulating fan motors are permanently lubricated by the motor manufacturer. These motors will have no oil ports. If the blower motor does contain oil ports, under normal operating conditions it will not require oiling for the first two years. Oil sparingly; a few drops in each oil port with SAE 20 non-detergent oil. Oiling is most easily done with a "tele-spout" oiler. This oiler has a long flexible plastic spout. **DO NOT OVER-LUBRICATE.** Excess oil may result in premature electric motor failure.

Inspect the blower fan. Clean it if necessary.

Oil Burner Maintenance: Follow the instructions of the oil burner manufacturer. (See oil burner manufacturer's instructions supplied with furnace). The oil burner nozzle should be replaced annually. We recommend that the oil filter be changed on an annual basis.

The venting system should be cleaned and inspected for signs of deterioration. Replace pitted or perforated vent pipe and fittings. The barometric damper should open and close freely.

All electrical connections should be checked to ensure tight connections. Safety controls such as the high limit controls should be tested for functionality. The fan control functions should be checked to ensure that all fan speeds are operating properly.

## 20. FURNACE INSTALLATION SET UP

The furnace must be set up as the final step in the installation.

A) The oil burner must be set up following the procedures outlined in section 17: Oil Burner Set Up.

B) The furnace should operate within a temperature rise of approximately 85°F. To determine the temperature rise, measure the supply air and return air temperatures when the furnace has reached steady state conditions. This is the point at which the supply air temperature stops increasing relative to the return air temperature. The furnace may have to run 10 to 15 minutes to reach steady state conditions. The measurements may be made with duct thermometers or thermocouples used in conjunction with multi-meters with temperature measurement capabilities.

The return air should be measured at a point where the thermometer will be well within the air stream near the furnace return air inlet. Actual location is not particularly critical; however, avoid locations where the temperature readings could be affected by humidifier bypass ducts, the inside radius of elbows, etc.

The supply air temperature should be measured at a point where the thermometer will be well within the air stream near the furnace supply air outlet. Usually, the side mid-point of the supply air plenum take-off is ideal, providing it is out of the line of sight to the heat exchanger. If the thermometer is within the line of sight of the heat exchanger, the supply air readings may be skewed by radiant heat from the heat exchanger. If the plenum take-off is unsuitable, the supply air temperature may be measured within the first 18 inches of the first segment of supply air trunk duct.

If the temperature rise is outside the recommended range, it may be adjusted on direct drive equipped units by selecting alternate circulation fan motor speeds, or on belt drive equipped units, by adjusting the variable speed motor pulley or by blower pulley changes. If the temperature rise is too high, speed the fan up. If the temperature rise is too low, slow the fan down.

C) Adjust the fan control. The easiest method to adjust the control is to first set the "fan off" control lever, and then adjust the "fan on" control lever based on the final setting of the "fan off" control lever. After the blower has run for a few minutes, lower the thermostat setting to extinguish the oil burner. The blower should ideally shut off at approximately 95°F,  $\pm 5^\circ$ , as measured by the duct thermometer indicating the supply air outlet temperature. If, for example, the observed "fan off" temperature is 110°F, move the "fan off" control lever approximately 1½ notches clockwise (to the left). Each notch represents

10°F. It may be necessary to run the furnace through one or two more cycles to ensure accuracy. Once the "fan off" setting has been established, set the "fan on" control lever approximately 30° warmer. The differential between the settings may be decreased for better efficiency; however, there is an increased chance that the blower will recycle for a few seconds after the oil burner has shut off because of the effect of residual heat in the heat exchanger radiating on the fan control. An increased difference between the "fan off" and "fan on" settings will decrease efficiency by allowing a larger proportion of generated heat to escape up the chimney.

D) Keep in mind that the stack temperature varies directly with the temperature rise. The higher the temperature rise, the higher the stack temperature will be, resulting in lower efficiency. The lower the temperature rise, the lower the stack temperature will be, which, in some cases, may allow condensation to form in the chimney and other vent parts.

E) Test the high limit control to ensure that it is operating correctly. This may be done by temporarily removing the circulator fan heating wire or neutral wire. On furnaces equipped with belt drive blowers, the fan belt may be temporarily removed. Turn off electrical power to the furnace before working with the motor wires. Be sure to protect any removed wires from shorting out on metal furnace parts. If the high limit test is successful, shut off the electrical power to the furnace, restore the proper motor wiring, or replace the fan belt. Finally, restore power to the furnace.

F) Operate the furnace through a minimum of three full heating cycles. During this time, check for fuel oil leaks, gross air leakage from the supply air ductwork, unusual noises originating anywhere within the heating system which may cause some concern or annoyance to the home owner, etc.

G) Be sure that the homeowner is familiar with the furnace. The homeowner should be aware of the location of electrical circuit breaker or fuse, the location of any electrical switches controlling the furnace, the location of the oil tank shut-off valve and how to operate the valve. The homeowner should be informed where the oil tank gauge is located and how to read it.

It would be beneficial to review safety issues with the home owner, such as the danger of storing combustibles too close to the furnace, hanging anything on the furnace vent pipe, and especially the dangers of indiscriminately pressing the burner reset button.

**IMPORTANT:** Be sure that the home owner knows where the burner reset switch is located, and is aware that the reset switch is not to be activated more than once without a thorough look for the cause of the problem, (lack of fuel, etc.). Be sure that the homeowner

knows when to quit trying to start the furnace during these conditions and who to call for emergency service.

## 21. OPERATING INSTRUCTIONS

### Before Lighting

Open all supply and return air registers and grilles.  
Open all valves in oil pipes.  
Turn on electric power supply.

### To Light Unit

Set the thermostat above room temperature to call for heat. The burner will start. NOTE: If the furnace has been off for an extended period of time, it may be necessary to press the RESET button on the primary combustion control relay, (once only). If pressing the reset button does not start the furnace, refer to Appendix C, Troubleshooting.

A few seconds after the thermostat calls for heat, (after the oil burner starts), the furnace becomes warm, the circulation fan will start.

The furnace will continue to run until the thermostat call for heat is satisfied.

Set the thermostat below room temperature. The oil burner will stop.

The air circulation blower will continue to run for a few seconds after the oil burner has stopped, until the temperature in the furnace has reached the "fan off" setting of the fan/limit switch.

### To Shut Down Unit

Set the thermostat to the lowest possible setting.  
Set the manual switch (if installed) in the Electrical Power Supply Line to "OFF".

NOTE: If the furnace is to be shut down for an extended period of time, close the oil supply valve to the oil burner.

 **WARNING**

**DO NOT ATTEMPT TO START THE BURNER WHEN EXCESS OIL HAS ACCUMULATED, WHEN THE FURNACE IS FULL OF VAPOUR, OR WHEN THE COMBUSTION CHAMBER IS VERY HOT. NEVER BURN GARBAGE OR PAPER IN THE FURNACE, AND NEVER LEAVE PAPER OR RAGS AROUND THE UNIT.**

# Appendix A DATA

### TABLE A-1 BECKETT AF OIL BURNER SET-UP

BECKETT AF SERIES OIL BURNERS							
FURNACE MODEL	OUTPUT BTU/Hr	BURNER MODEL	NOZZLE (Delavan)	PUMP PRESSURE	FLOW RATE	HEAD	STATIC PLATE
145F	130,000	AF65YB	1.10 / 70°A	100 PSIG	1.10 US GPH	F6	2-3/4 in.
145F	143,000	AF65YB	1.20 / 60°A	100 PSIG	1.20 US GPH	F6	2-3/4 in.
145R	130,000	AF65YB	1.10 / 70°A	100 PSIG	1.10 US GPH	F6	2-3/4 in.
145R	143,000	AF65YB	1.20 / 60°A	100 PSIG	1.20 US GPH	F6	2-3/4 in.
190R	168,000	AF81WF	1.50 / 70°B	100 PSIG	1.50 US GPH	F16	2-3/4 in.
190R	188,000	AF81WF	1.65 / 70°B	100 PSIG	1.65 US GPH	F16	2-3/4 in.
225R	196,000	AF81WF	1.75 / 70°B	100 PSIG	1.75 US GPH	F16	2-3/4 in.
225R	224,000	AF81WF	2.00 / 70°B	100 PSIG	2.00 US GPH	F16	2-3/4 in.

In the United States, the R. W. Beckett "AF" Burner may be equipped with Beckett's "Inlet Air Shut-Off", Beckett Part No. AF/A 5861, to increase efficiency. It reduces the amount of air passing through the oil burner, combustion chamber, breeching, etc. up the chimney between burner cycles.

**NOTE: THE USE OF THIS CONTROL CAN OCCASIONALLY CAUSE POST COMBUSTION NOZZLE DRIP.**

### TABLE A-2 RIELLO 40F OIL BURNER SET-UP

RIELLO 40 F SERIES OIL BURNERS							
FURNACE MODEL	OUTPUT BTU/Hr	BURNER MODEL	NOZZLE (Delavan)	PUMP PRESSURE	FLOW RATE	TURBULATOR	AIR DAMPER
145F	130,000	40 F5	1.00 / 60° W	125 PSIG	1.11 GPH	4.3	2.0
145F	143,000	40 F5	1.10 / 60° W	125 PSIG	1.23 GPH	5.9	2.5
145R	130,000	40 F5	1.00 / 60° W	125 PSIG	1.11 GPH	2.0	4.3
145R	143,000	40 F5	1.10 / 60° W	125 PSIG	1.23 GPH	2.5	5.9



**TABLE A-3 DIRECT DRIVE BLOWER SET-UP**

FURNACE OUTPUT BTU/Hr.	BLOWER	MOTOR HP	BLOWER SET-UP			COOLING CAPACITY		
			0.20 in. w.c.	0.50 in w.c.	Htg. CFM Range <sup>1</sup>	Tons <sup>2</sup>	MOTOR HP	Clg. CFM Range
			Speed	Speed				
<b>LHO-145FDx4 – LHO-145RDx4</b>								
130,000	G10 DD	½	High	High	1198 – 1712	3 – 4	½	1000 – 1600
143,000			High	High	1318 – 1883			
<b>LHO-145FDx5 – LHO-145RDx5</b>								
130,000	DCT 1220- 1104-5T	1	Medium	Medium	1198 – 1712	3 - 5	1	1300 – 2000
143,000			High	High	1318 – 1883			
<sup>(1)</sup> Heating Range values based on temperature rise. Upper values may exceed measured airflow values in Table A-3. <sup>(2)</sup> Nominal Values Only								

**TABLE A-4 BELT DRIVE BLOWER SET-UP**

Furnace Output BTU/Hr.	Blower	Blower Set-Up							Cooling Capacity			
		0.20 in. w.c.				0.50 in. w.c.			Tons	Motor	CFM Range	
		Pulley		Belt	Motor	Pulley		Belt				Motor
		Motor	Blower			Motor	Blower					
<b>LHO-145FBx4 - LHO-145RBx4</b>												
130,000	G10	3¼ x ½	6 x ¾	4L410	1/2 HP	3¼ x ½	5 x ¾	4L390	1/2 HP	2½ - 3½	1/2 HP	900 - 1450
143,000	G10	3¼ x ½	6 x ¾	4L410	1/2 HP	3¼ x ½	5 x ¾	4L390	1/2 HP	2½ - 3½	1/2 HP	900 - 1450
<b>LHO-190RBx4</b>												
170,000	G12	3½ x ¾	7 x ¾	4L430	3/4 HP	3½ x ¾	7 x ¾	4L430	3/4 HP	3 - 4	3/4 HP	1300 – 1550
190,000	G12	3½ x ¾	7 x ¾	4L430	3/4 HP	3½ x ¾	7 x ¾	4L430	3/4 HP	3 - 4	3/4 HP	1300 – 1550
<b>LHO-190RBx5</b>												
170,000	G12	3½ x ¾	6 x ¾	4L410	1 HP	3½ x ¾	6 x ¾	4L410	1 HP	3 - 5	1 HP	1600 – 2200
190,000	G12	3½ x ¾	6 x ¾	4L410	1 HP	3½ x ¾	6 x ¾	4L410	1 HP	3 - 5	1 HP	1600 – 2200

**Table A-5: Airflow Characteristics – Direct Drive**

Furnace Model	Motor HP	Blower	$\Delta T$	Motor FLA	Speed	CFM					
						External Static Pressure – Inches w.c.					
						0.20	0.25	0.30	0.40	0.50	0.60
LHO-145FDx4 LHO-145RDx4	1/2 HP	G10 DD	85°F	7.0	High	1810	1775	1740	1675	1585	1510
					Med-High	1570	1555	1540	1495	1445	1375
					Med-Low	1090	1085	1080	1070	1065	1050
					Low	710	700	700	690	665	650
LHO-145FDx5 LHO-145RDx5	1 HP	DCT1220-1104-5	85°F	12.3 14.0 MAX	High	2188	2161	2133	2069	2016	1933
					Medium	1742	1730	1718	1702	1670	1604
					Low	1410	1410	1410	1390	1374	1326

**Table A-6: Airflow Characteristics – Belt Drive**

Furnace Model	Motor HP	Motor FLA	$\Delta T$	Blower	Blower Pulley	Motor Pulley Turns Out	CFM					
							External Static Pressure – Inches w.c.					
							0.20	0.25	0.30	0.40	0.50	0.60
LHO-145FBx4 LHO-145RBx4	1/2 HP	7.8	85°F	G10	6 x ¾	0	1535	1475	1410	1250	1065	845
						2	1440	1370	1295	1090	880	472
						4	1320	1250	1170	970	625	319
						6	1225	1140	1040	835	435	132

Continued on next page.

**Table A-6: Airflow Characteristics – Belt Drive** continued

Furnace Model	Motor HP	Motor FLA	ΔT	Blower	Blower Pulley	Motor Pulley Turns Out	CFM					
							External Static Pressure – Inches w.c.					
							0.20	0.25	0.30	0.40	0.50	0.60
LHO-190RBx4	3/4 HP	13.0	85°F	G12	7 x ¾	0	2274	2177	2080	1847	1532	1099
						2	2107	2017	1927	1712	1420	1019
						4	1939	1857	1775	1576	1308	939
						6	1772	1697	1622	1441	1196	859
LHO-190RBx5	1 HP	14.0	85°F	G12	6 x ¾	2	2601	2525	2449	2334	2164	2007
						3	2549	2474	2399	2288	2120	1967
						4	2497	2424	2350	2241	2077	1927
						5	2444	2373	2301	2194	2034	1887

These formulae will assist with the design of the ductwork and the determination of airflow delivery:

$$CFM = \frac{\text{Bonnet Output}}{(1.085 \times \text{System Temperature Rise})}$$

$$\text{System Temperature Rise} = \frac{\text{Bonnet Output}}{(1.085 \times CFM)}$$

# GENERAL DIMENSIONS: LHO-145 MODELS

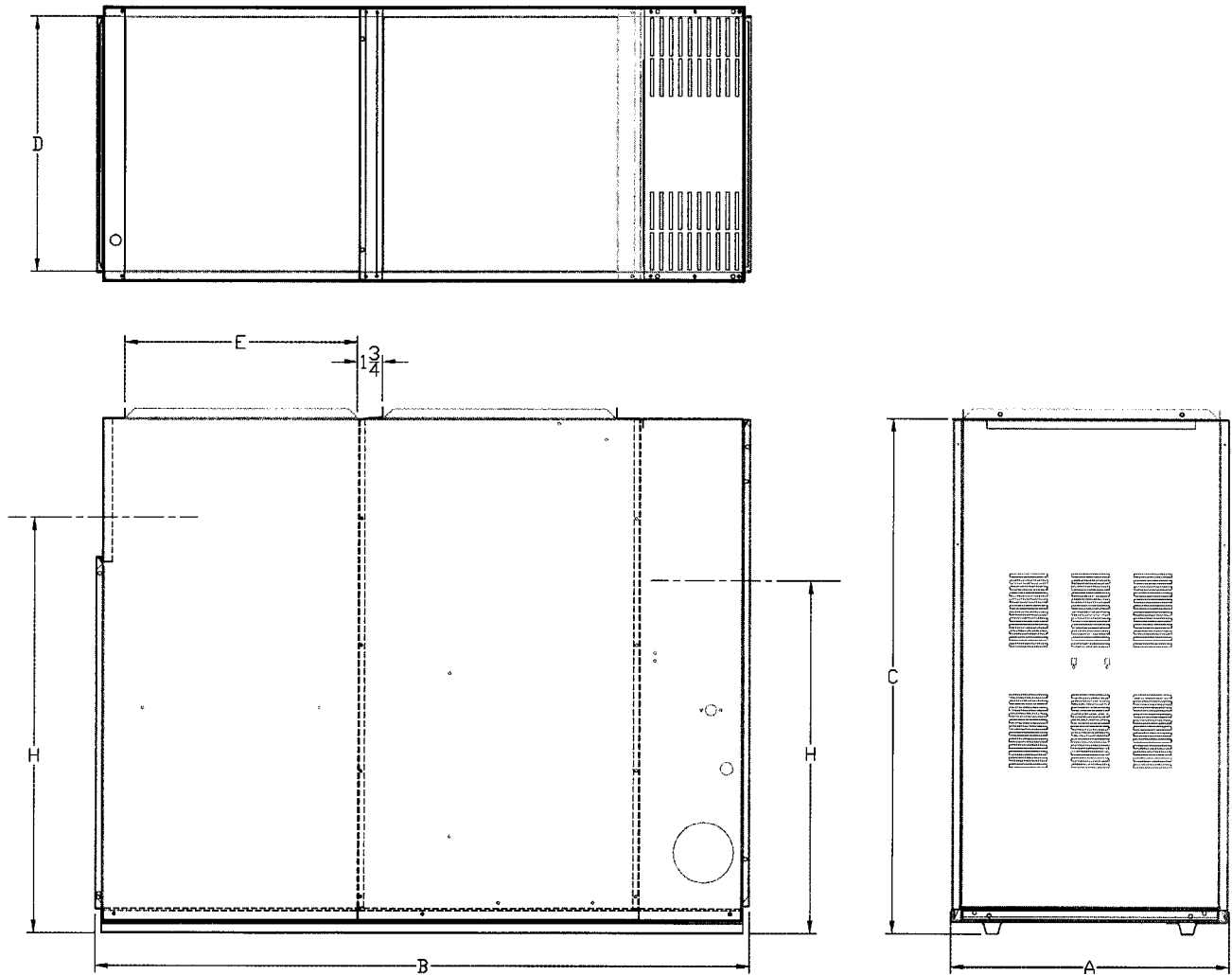

**Table A-7: General Dimensions (inches)**

Cabinet			Plenum Openings		Flue		Filter (Perm)	Ship Weight (lb.)
Width A	Length B	Height C	Supply D x E	Return F x G	Dia.	Height H		
LHO-145F								
22	51-1/2	41	20½ x 18	20½ x 18	6	38 <sup>±0.5</sup>	20 x 25 x 1	290
LHO-145R								
22	51-1/2	41	20½ x 18	20½ x 18	6	34	20 x 25 x 1	290

**GENERAL DIMENSIONS: LHO-190 MODELS**

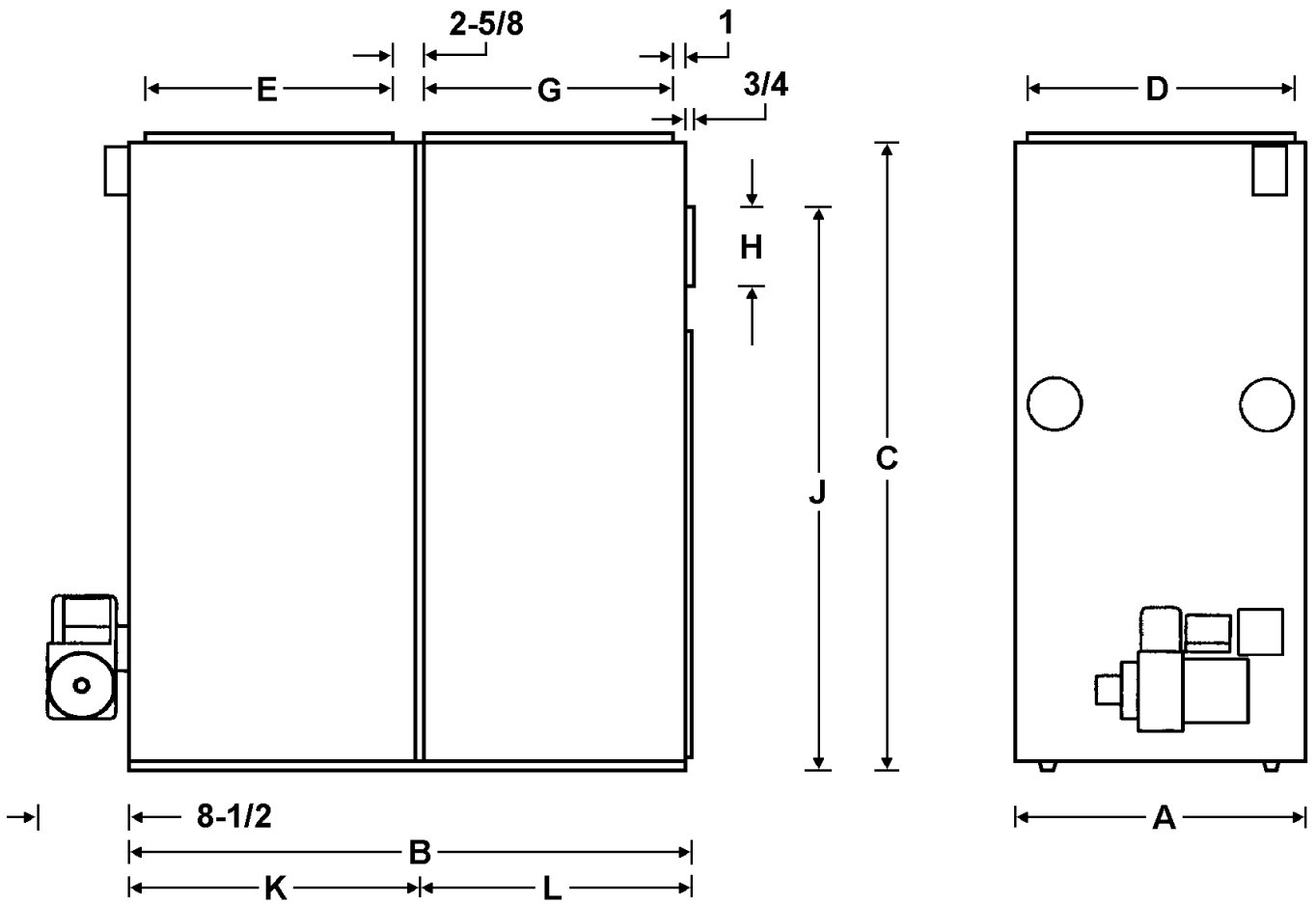

Cabinet			Plenum Openings		Flue		Filter (Perm)	Ship Weight (lb.)
Width A	Length B	Height C	Supply D x E	Return D x G	Diam. H	Height J		
LHO-190								
26	46	56	24 x 22	24 x 22	7	50¼	20 x 25 x 1 (2)	390
Furnace Section								
26	22½ (K)	56	Add 8½" to "K" for Burner Assembly					
Blower Section								
26	23½ (L)	56						

# Appendix B WIRING

## WIRING DIAGRAM:

### LEGEND/legende

	120 V	FACTORY WIRING
	24 V	Filage a l'usine
	120 V	FIELD WIRING
	24 V	Filage au champs

- GROUND/Terre
- TERMINAL PROVIDED/  
point de raccord fourni
- TERMINAL NOT PROVIDED/point  
de raccord non-fourni

BK	BLACK/noir	VI	VIOLET/violet
BL	BLUE/bleu	WH	WHITE/blanc
BR	BROWN/brun	YL	YELLOW/jaune
GR	GREEN/vert	GND	GROUND/Terre
OR	ORANGE/orange	CAP	CAPACITOR/capaciteur
RD	RED/rouge		

AUXILIARY LIMIT (IF EQUIPPED)  
limite auxiliaire - si éééééé

LIMIT/limite

LOW SPEED FAN SWITCH (IF EQUIPPED)  
interrupteur a basse vitesse (si éééééé)

BLOCKED VENT SAFETY  
(REQUIRED FOR CANADIAN INSTALLATIONS)  
commande d'épreuve de système d'évacuation bloqué  
(requis pour les installations au Canada)

IGNITER/  
transformateur d'allumage

VALVE/  
soupappe

L1  
POWER SUPPLY 120 VAC 60 HZ  
(FUSED DISCONNECT ON HOT LEG)  
alimentation 120 VAC 60Hz  
(disjoncteur avec fusible sur le fil d'alimentation)

BELT DRIVE MOTOR ventilateur a courroie  
(IF AVAILABLE) (si disponible)

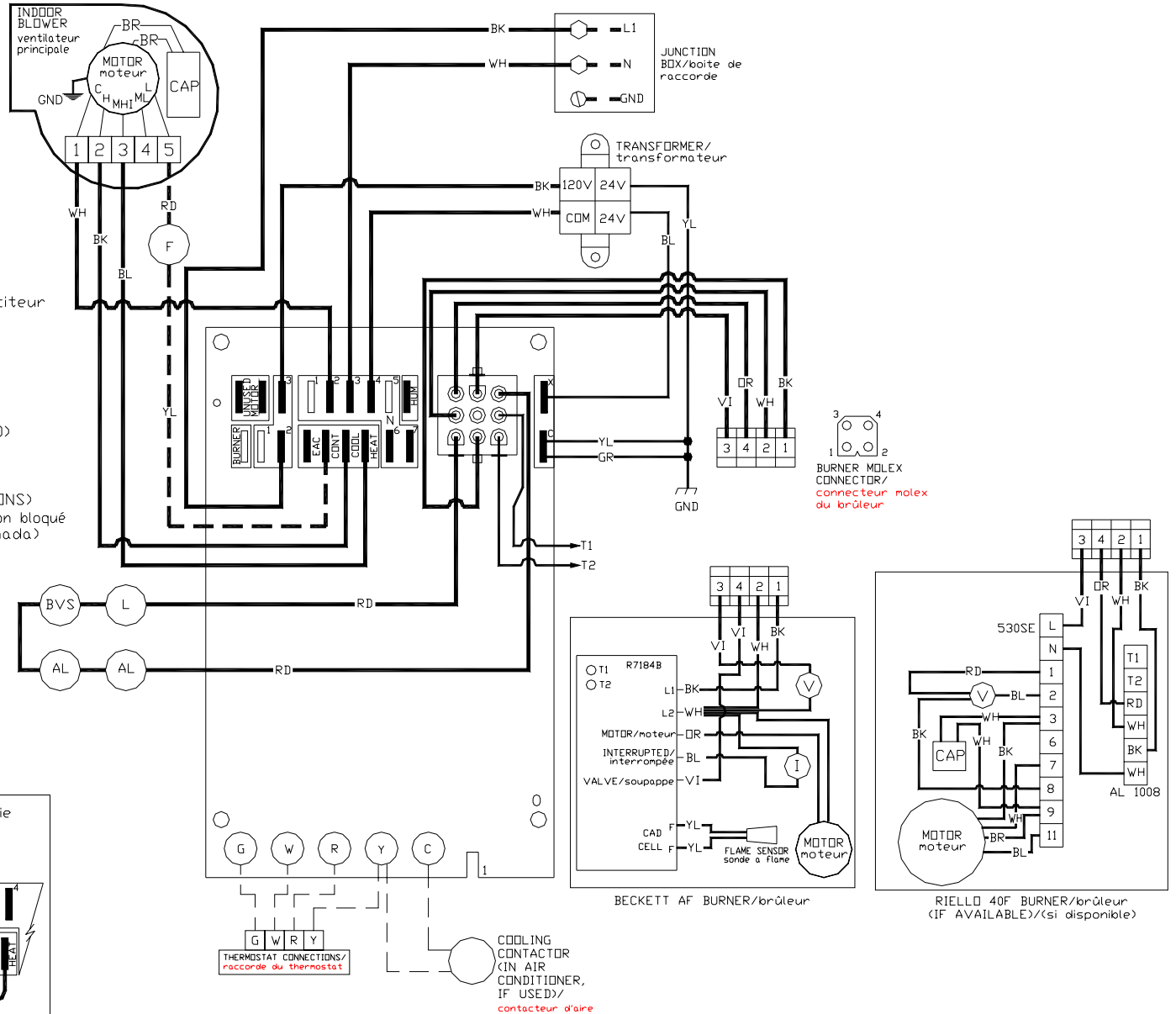
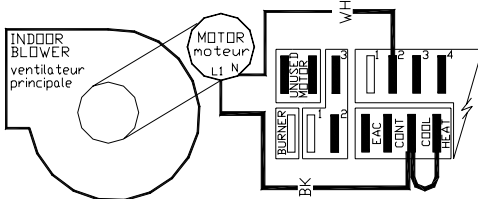

## Appendix C

### TROUBLESHOOTING

#### R7184 DETAILED SEQUENCE OF OPERATION

Power is applied to unit. The R7184 completes a self-diagnostic procedure. If no light or flame is present, and unit passes its self-diagnostic procedure, the control enters into the idle mode.

*Thermostat calls for heat:*

- A. Safety check is made for flame (4 second delay).
  1. When flame is not present, the R7184 will apply power to the burner motor and igniter.
  2. When flame is present, the control remains in the idle state.
- B. Unit enters and completes a pre-purge period of 15 seconds, then applies power to the solenoid valve.
- C. Control enters the trial for ignition state.
- D. Control monitors the burner flame.
  1. When flame is present, the control enters ignition carryover state. (Continues to spark for 10 sec.).
    - a. Provides continuous spark after flame is sensed to assure that burner remains lit.
    - b. Turns on LED diagnostic light.
    - c. Starts carryover timer.
      - i. Flame and call for heat are monitored.
        - If flame is lost and lockout timer has not expired, R7184 will return to trial for ignition state.
        - If flame is lost and lockout timer has expired, R7184 will enter the recycle state.
          - ◆ Recycle timer starts.
          - ◆ Burner motor and igniter and solenoid valve are turned off.
          - ◆ LED diagnostic light flashes slow.
          - ◆ Returns to idle state when recycle timer expires (60 seconds).
- E. Carryover timer expires.
  - i. Enters run state.
    - Igniter turns off.

*Combustion continues until thermostat is satisfied, or R7184 detects a loss of flame and enters into Recycle Mode.*

*Thermostat is satisfied - call for heat is terminated:*

- R7184 shuts off burner motor and solenoid valve.
- LED diagnostic light is off.
- R7184 returns to idle state.

Please see flow chart on page 31.

**R7184  
SEQUENCE of  
OPERATION**

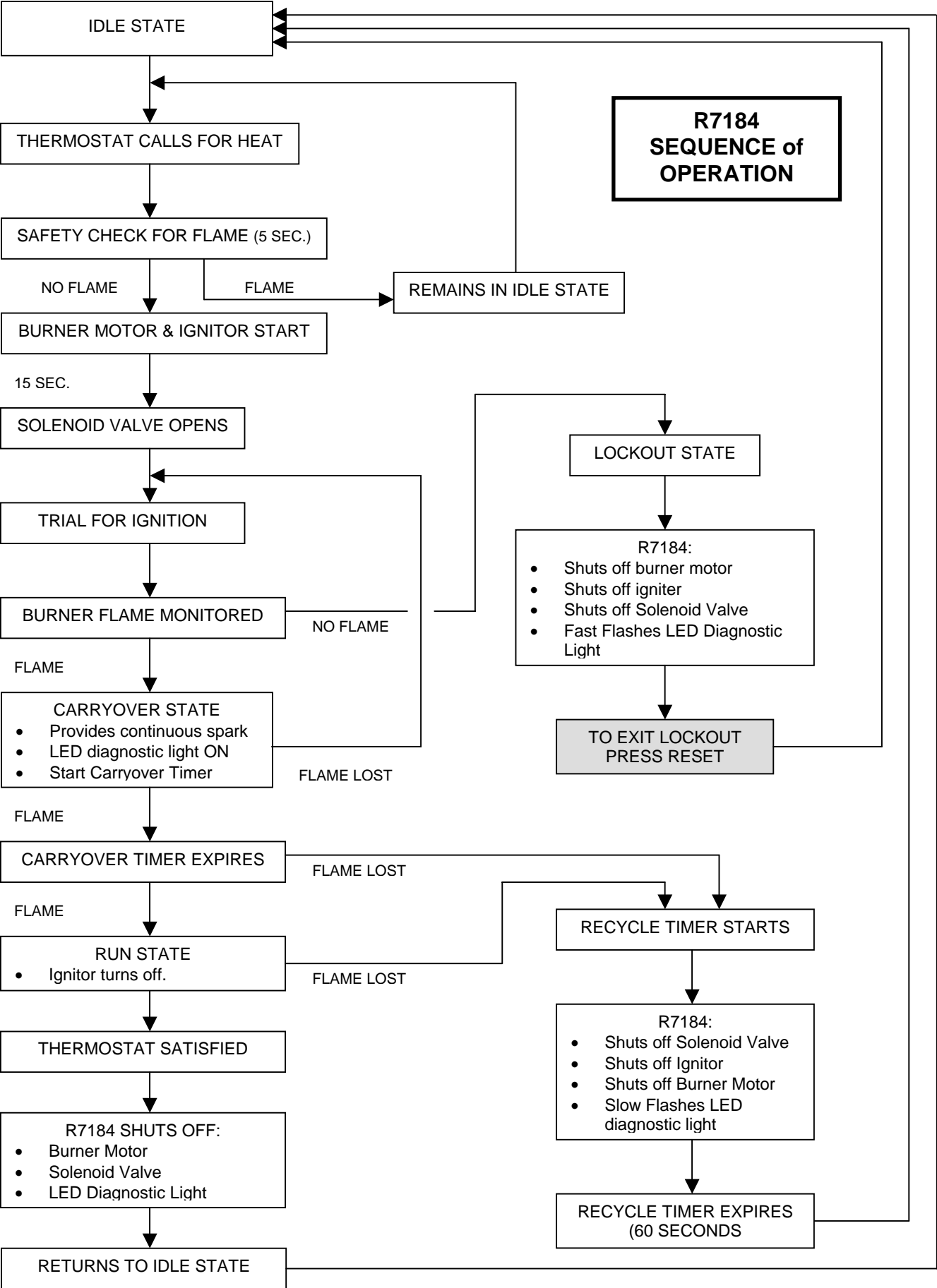



# RIELLO 40F3 TROUBLESHOOTING CHART

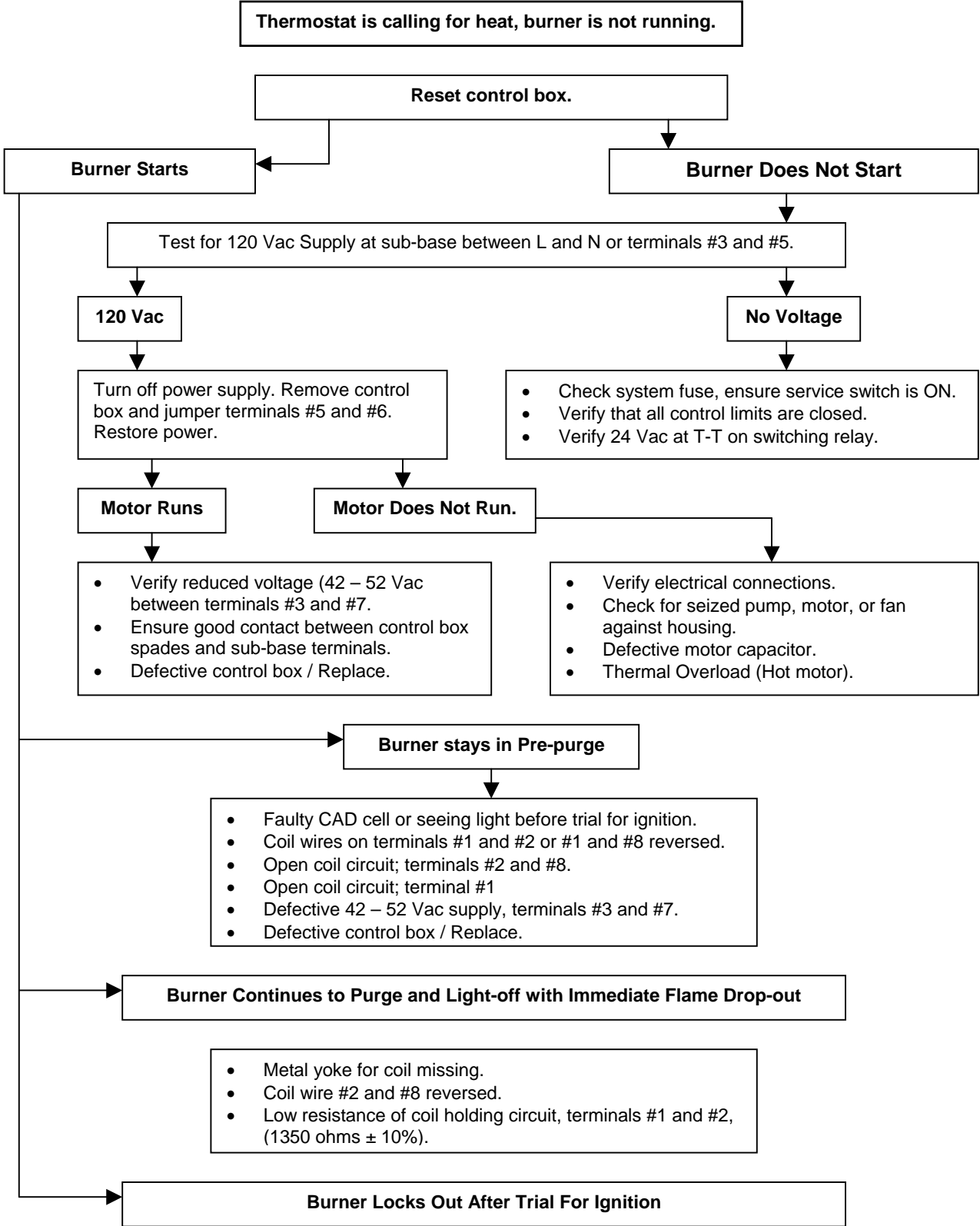

Continued on next page.

### Burner Locks Out After Trial For Ignition

- Low resistance or no contact on starting circuit of coil, terminals #2 and #8. (1.3 ohm  $\pm$  %).
- No oil supply – tank empty, valve closed, dirty filter, damaged supply lines.
- Defective or dirty oil valve stem, nozzle, or pump strainer.
- Broken pump drive key, defective pump, no oil pressure.
- Ignition electrodes shorted, cracked porcelain.
- Burner motor not up to speed.
- Excessive draft over fire.
- Defective control box / Replace.

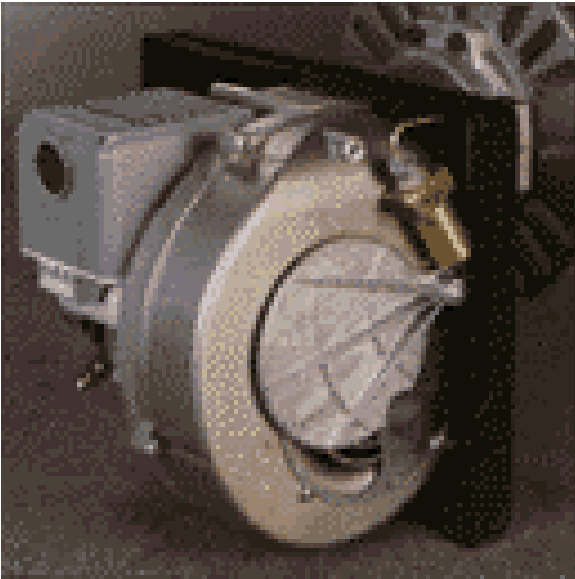

Riello Oil Burner Automatic Air Shutter.

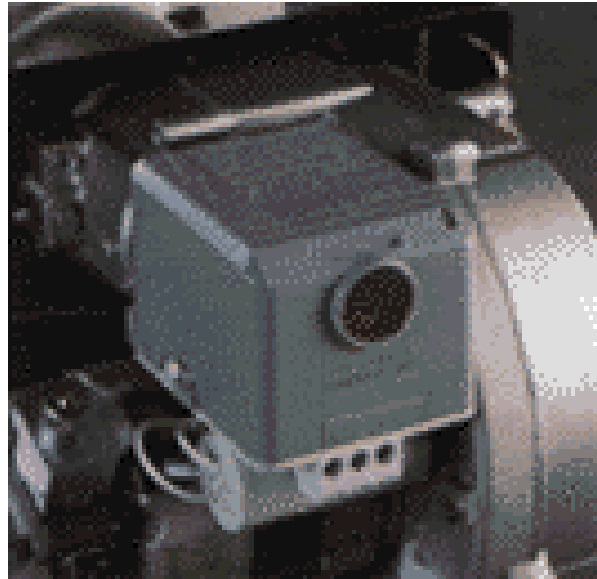

Riello Oil Burner Electronic Ignition Control.

## R7184 LED DIAGNOSTIC LIGHT

The LED diagnostic light has several functions. It indicates the state or mode in which the oil burner is operating. It will also indicate fault conditions, and help determine cad cell resistance while the burner is operating.

### NORMAL CONDITIONS:

The LED diagnostic light will turn on when the burner enters the carryover state; the point at which ignition spark is on, and will remain on through the run state, where the ignition spark is terminated but the burner continues to fire.

The LED diagnostic light will turn off at the end of the burner cycle as the R7184 enters the idle state, and will remain off until the next heating cycle.

### FAULT CONDITIONS:

If the LED diagnostic light is flashing quickly; 1 Hz ( $\frac{1}{2}$  second on /  $\frac{1}{2}$  second off), the R7184 is in the lockout state or in restricted mode. To exit the lockout state, press the reset button.

If the LED diagnostic light is flashing slowly;  $\frac{1}{4}$  Hz (2 seconds on / 2 seconds off), the R7184 is in the recycle state. This indicates that flame sensing was lost after the lockout timer expired during the ignition carryover state. The R7184 will return to the idle state within 60 seconds.

### CAD CELL CONDITION:

If the LED diagnostic light is off, the cad cell is not sensing flame.

If the LED diagnostic light is on, the cad cell is sensing flame, or viewing ambient light.

The resistance of the cad cell may be checked while the R7184 is in the run state by pressing the reset button. The LED diagnostic light will flash the following code:

**TABLE C-1: CAD CELL RESISTANCE**

Flashes	Resistance in Ohms
1	Less than 400
2	Between 400 - 800
3	Between 800 – 1600
4	Between 1600 - 5000

## Troubleshooting

### IMPORTANT:

**Due to the potential hazard of line voltage, only a trained, experienced service technician should perform the troubleshooting procedure.**

### PRELIMINARY STEPS:

Check the diagnostic light for indications of burner condition. Refer to R7184 LED DIAGNOSTIC LIGHT section for details.



When simulating a call for heat at the R7184, disconnect at least one thermostat lead wire from the T1 - T2 terminals to prevent damage to the thermostat. Neglecting this procedure may burn out the heat anticipator of a standard 24 VAC thermostat, or cause harm to components within a micro-electronic thermostat.

Before checking the oil primary control, perform these preliminary checks, (repair or replace controls as necessary):

- check the power supply; fuse box or breaker, any service switches, all wiring connections, and burner motor reset button (if equipped).
- check the limit switches to ensure that the switch contacts are closed.
- check the electrode gap and position.
- check the contacts between the oil primary control and the electrodes.
- check oil supply (tank gauge).
- check the oil nozzle, oil filter, and oil valves.
- check the piping or tubing to the oil tank.
- check the oil pump pressure.

CHECK OIL PRIMARY CONTROL AND IGNITOR

If the trouble does not appear to be in the burner or ignition hardware, check the oil primary control and the ignitor by using the following equipment:

- ◇ screwdriver.
- ◇ voltmeter (0 - 150 VAC)
- ◇ insulated jumper wires with both ends stripped.



**Electrical Shock Hazard.**

Troubleshooting is done with the system powered. Be careful to observe all necessary precautions to prevent electrical shock or equipment damage.

**Preliminary Checks:**

1. Make sure that limit switches are closed and that contacts are clean.
2. Check for line voltage power on the oil primary control black and white lead wires.
3. Refer to Table C-4 or C-5 for further troubleshooting information.

**TABLE C-2: R7184 TROUBLESHOOTING**

**Condition: Burner motor does not start when there is a call for heat.**

Procedure	Status	Corrective Action
1. Check that limit switches are closed and contacts are clean. This includes the burner motor reset button.	N/A	N/A
2. Check for line voltage power at the oil primary control. Voltage should be 120 Vac between the black and white lead wires on the oil primary control.	N/A	N/A
3. Check indicator light with burner off, no call for heat (no flame).	Indicator light is on.	Cad cell is defective, sees external light, or connections have shorted. Go to step 4.
	Indicator light is off.	Go to step 5.
4. Shield cad cell from external light.	Indicator light turns off.	Eliminate external light source or permanently shield cad cell.
	Indicator light stays on.	<ul style="list-style-type: none"> <li>• Replace cad cell with new cad cell and recheck.</li> <li>• If indicator light does not turn off, remove yellow leadwires from R7184 and recheck.</li> <li>• If indicator light is still on, replace the R7184 control.</li> <li>• If the indicator light turns off, replace cad cell bracket assembly.</li> </ul>

- *continued on following page*

• **Table C-2: R7184 Troubleshooting** *continued from previous page*

Procedure	Status	Corrective Action
5. Jumper thermostat (T -T) terminals on R7184  <b>IMPORTANT</b> First remove one thermostat lead wire.	Burner starts.	Trouble is in thermostat circuit. Check thermostat wiring connections. If connections are clean and tight, check thermostat wires for continuity.
	Burner does not start.	<ul style="list-style-type: none"> <li>• Disconnect line voltage power and open line switch.</li> <li>• Check all wiring connections.</li> <li>• Tighten any loose connections and recheck.</li> <li>• If burner still doesn't start, replace R7184</li> </ul>
		If burner still doesn't start, check the oil burner motor. It may be seized or burned out.
<b>Condition: Burner starts then locks out on safety with indicator light flashing at 1 Hz rate (½ second on, ½ second off)</b>		
Procedure	Status	Corrective Action
1. Check that the limit switches are closed and contacts are clean.	---	---
2. Check for line voltage power at the oil primary control. Voltage should be 120 vac (nominal)	---	---
3. Check indicator light with burner off, no call for heat (no flame).	Indicator light is on.	Cad cell or controller is defective, sees external light, or connections are shorted. Go to step 4.
	Indicator light is off.	Go to step 5.
4. Shield cad cell from external light.	Indicator light turns off.	Eliminate external light source or permanently shield cad cell.
	Indicator light stays on.	<ul style="list-style-type: none"> <li>• Replace cad cell with new cad cell and recheck.</li> <li>• If indicator light does not turn off, remove cad cell leadwires from R7184 and recheck.</li> <li>• If indicator light turns off, replace cad cell bracket assembly.</li> <li>• If indicator light does not turn off, replace controller.</li> </ul>

*Continued on next page*

**Table C-2: R7184 Troubleshooting** *continued from previous page*

Procedure	Status	Corrective Action
5. Jumper thermostat (T -T) terminals on R7184  <b>IMPORTANT</b> First remove one thermostat lead wire.	Burner starts.	Trouble in thermostat or limit circuit. Check thermostat or limit wiring connections.
	Burner does not start.	<ul style="list-style-type: none"> <li>• Disconnect the line voltage power and open line switch.</li> <li>• Check all wiring connections.</li> <li>• Tighten any loose connections and recheck.</li> <li>• If burner does not start, replace R7184</li> </ul>
<b>Condition: Burner starts then locks out on safety with indicator light flashing at 1 hz rate (½ second on, ½ second off)</b>		
6. Reset oil primary control by pushing in and releasing red reset button.	Indicator light stops flashing.	Go to Step 7.
	Indicator light continues to flash at 1 Hz rate.	Verify that the control is not in restricted mode. (See notes at end of this table.). If not in restricted mode, replace R7184
7. Listen for spark after burner turns on (after 2 second delay).	Ignition is off	Spark ignitor could be defective. Check for line voltage at ignitor terminals. If line voltage is present, replace R7484.
	Ignition is on.	Go to Step 8.
	Ignition is on but no oil is being sprayed into the combustion chamber.	Wait for "Valve ON" delay to complete. Check oil supply, and oil line valve. Check for filter blockage or seized oil pump.
8. Check indicator light after flame is established, but before oil primary control locks out.	Indicator light is on until the control locks out and starts flashing during lockout.	Replace R7184
	Indicator light stays off.	Go to step 9.

*Continued on next page*

**Table C-3: R7184 Troubleshooting** *continued from previous page*

Procedure	Status	Corrective Action
<p>9. Check cad cell sighting for view of flame.</p> <ul style="list-style-type: none"> <li>• Disconnect line voltage power and open line switch.</li> <li>• Unplug cad cell and clean cad cell face with soft cloth. Check sighting for clear view of flame. Replace cad cell in socket.</li> <li>• Reconnect line voltage power and close line switch.</li> <li>• Start burner.</li> </ul>	Burner locks out.	Go to step 10.
	Burner keeps running.	System is OK.
<p>10. Check cad cell.</p> <ul style="list-style-type: none"> <li>• Disconnect line voltage power and open line switch.</li> <li>• Remove existing cad cell and replace with new cad cell.</li> <li>• Disconnect all wires from thermostat terminals to ensure that there is no call for heat.</li> <li>• Reconnect line voltage power and close line switch.</li> <li>• Expose new cad cell to bright light such as a flashlight.</li> </ul>	Indicator light is on.	Remount control onto burner housing. Go to step 6.
	Indicator light is off.	Go to step 11.

*Continued on next page.*

**Table C-2: A Troubleshooting** *continued from previous page.*

Procedure	Status	Corrective Action
11. Check cad cell bracket assembly. <ul style="list-style-type: none"> <li>• Disconnect line voltage power and open line switch.</li> <li>• Remove cad cell wires from quick connect connectors on the and leave control leadwires open.</li> <li>• Apply power to device.</li> <li>• Place jumper across cad cell terminals after burner motor turns on.</li> </ul>	Indicator light is on.	Replace cad cell bracket assembly.
	Indicator light is off.	Replace R7184.
<p>NOTE: Restricted Mode - (Limited Reset): In order to limit the accumulation of unburned oil in the combustion chamber, the control can be reset only 3 times, after which, the control locks out. The reset count returns to zero each time a call for heat is successfully completed.</p> <p>To reset from RESTRICTED MODE: press and hold the reset button for 30 seconds. When the LED flashes twice, the device has reset.</p>		
<p>NOTE: Disable function: Pressing and holding the reset button will disable all functions until the button is released. The will restart at the beginning of the normal heat cycle on SAFETY CHECK.</p>		

**TABLE C-3: SYSTEM AND GENERAL TROUBLESHOOTING**

Problem	Possible Cause	Remedy
Furnace will not start.	Thermostat not calling for heat.	Check thermostat and adjust. Also, check thermostat for accuracy; if it is a mercury switch type, it might be off level.
	No power to furnace.	Check furnace switch, main electrical panel furnace fuse or circuit breaker. Also look for any other hand operated switch, such as an old poorly located furnace switch which was not removed during furnace replacement.
	Thermostat faulty.	Remove thermostat wires from oil primary control terminals T-T. Place a jumper across T-T. If furnace starts, replace thermostat, thermostat sub-base (if equipped), or both.
	Oil primary control faulty.	Check reset button on oil primary control. Remove thermostat wires from oil primary control terminals T1 - T2. Check for 24v across T -T. If no voltage is present, check for 115v to oil primary control. If 115v is present, go to Table C-3.
	Photo Cell wiring shorted or room light leaking into photo cell compartment	Check photo cell (cad cell) wiring for short circuits. Also, check for room light leaking into cad cell compartment. Repair light leak if necessary. See Table C-3.
	Open safety switch.	Check for open limit or auxiliary limit. Also, check internal wiring connections; loose connectors, etc.

*Continued on next page*



**TABLE C-3: SYSTEM & GENERAL TROUBLESHOOTING,** *continued from previous page*

<b>Problem</b>	<b>Possible Cause</b>	<b>Remedy</b>
Furnace will not start without first pushing oil primary control reset button. (Happens on frequent basis)	No fuel oil.	Check fuel oil supply. Check that all hand operated fuel oil valves are in the open position. Fill oil storage tank if necessary.
	Clogged nozzle.	Replace nozzle with high quality replacement. Use rating plate or Tables in Appendix A as a guide.
	Clogged oil filter.	Replace oil tank filter or in-line filter if used.
	Low oil pump pressure.	Connect pressure gauge to oil pump. Adjust pump pressure, or replace oil pump if necessary. Ensure that erratic pressure readings are not caused by defective fuel oil line.
	Air getting into fuel oil lines, or fuel oil line dirty, clogged, or in some manner defective.	Check fuel oil lines. Replace any compression fittings found with high quality flared fittings. Check for any signs of oil leaks. Any oil leak is a potential source of air or contaminants.
	Defective burner motor.	Check burner motor. If burner motor is cutting out on over-load, determine why. Replace if necessary.
Furnace starts, but cuts out requiring manually resetting the oil protector reset button.	Photo Cell (Cad Cell) defective.	If cad cell is dirty, clean it. (Determine why cad cell is getting dirty). If cad cell is poorly aimed, realign it. NOTE: The photocell should have a resistance of 100K $\Omega$ in absence of light; a maximum of 1500 $\Omega$ in the presence of light. Ensure that room light is not leaking into the cad cell compartment. (see diagnostic light section).
Furnace starts, but cuts out requiring manually resetting the oil protector reset button.	No fuel oil.	Check fuel oil supply. Check that all hand operated fuel oil valves are in the open position. Fill oil storage tank if necessary.
	Clogged nozzle.	Replace nozzle with high quality replacement. Use rating plate or Tables in Appendix A as a guide.
	Clogged oil filter.	Replace oil tank filter or in-line filter if used.
	Low oil pump pressure.	Connect pressure gauge to oil pump. Adjust pump pressure, or replace oil pump if necessary. Ensure that erratic pressure readings are not caused by defective fuel oil line.
	Air getting into fuel oil lines, or fuel oil line dirty, clogged, or in some manner defective.	Check fuel oil lines. Replace any compression fittings found with high quality flared fittings. Check for any signs of oil leaks. Any oil leak is a potential source of air or contaminants.
	Defective burner motor.	Check burner motor. If burner motor is cutting out on over-load, determine why. Replace if necessary.
	Water or contaminants in oil.	Drain fuel oil storage tank, replace fuel oil. (Consult with fuel oil supplier).
	Frozen oil line.	Gently warm oil line. Insulate oil line. (Outdoor piping size may require increased diameter).

*Continued on next page*

**TABLE C-3: SYSTEM & GENERAL TROUBLESHOOTING,** *continued from previous page*

<b>Problem</b>	<b>Possible Cause</b>	<b>Remedy</b>
Oil burner sputtering at nozzle	Electrodes out of adjustment or defective.	Check electrode settings. check electrodes for dirt build-up or cracks in porcelain.
	Poor igniter high voltage connections or defective igniter.	Check contacts between the igniter and electrodes. If OK, replace the igniter
	Fuel oil filter clogged.	Replace fuel oil storage tank filter and / or fuel oil in-line filter.
	Defective oil pump.	Check burner motor / fuel oil pump coupling. Check oil pump pressure. Replace fuel oil pump if necessary.
	Fuel oil line partially clogged or contains air.	Bleed air from oil line. If problem persists, replace oil line.
Excessive fuel oil consumption.	System temperature rise too high.	System temperature rise ideally should not exceed 85°F. Check for clogged air filters. Check blower fan for excess dirt build-up or debris. Speed up blower fan if necessary.
	Poor "fan off" delay timing selection, (fan stops too soon).	Check "fan off" delay timing setting. Use a duct thermometer in the supply air plenum take-off or first few inches of the supply air trunk duct. Ideally, the fan will shut off at a temperature of 90° - 100°F. Manipulate the dip switch settings to come as close as possible to this "fan off" temperature.
	Fuel oil leak.	Check fuel oil line for leaks. Repair or replace if necessary.
	Stack temperature too high.	Check stack temperature. Stack temperatures will normally range from 350° to 450°F. Check draft regulator. Draft should be set to 0.02 in. w.c.
	Thermostat improperly adjusted or in poor location.	Check thermostat heat anticipator setting against measured amperage draw. Increase heat anticipator setting if necessary. If the thermostat is being influenced by drafts, sunlight, duct work, etc., relocate to more suitable location.
Too much smoke.	Insufficient combustion air adjustment at oil burner, or improper draft pressure.	Adjust the oil burner combustion air band and draft regulator to gain the highest practical CO <sub>2</sub> or lowest practical O <sub>2</sub> content in the flue gases. See Burner Set Up.
	Heat exchanger partially clogged.	Check for soot build-up in heat exchanger flue passages, especially in the outer radiator.
Soot building up on blast tube (end coning).	Poor alignment between oil burner blast tube and fire pot.	Check alignment. blast tube should be centered with fire pot burner opening. Oil burner head should be ¼ inch back from the inside surface of the fire pot.
	Flame impingement caused by Incorrect nozzle angle.	Check nozzle size and angle. (See Appendix A). Check distance from head to inside surface of the fire pot.
	Defective fire-pot	Check fire-pot. Repair or replace.

*Continued on next page*

**TABLE C-3: SYSTEM & GENERAL TROUBLESHOOTING,** *continued from previous page*

<b>Problem</b>	<b>Possible Cause</b>	<b>Remedy</b>
Furnace will not warm home to desired temperature.	Airflow blocked or dirty air filter.	Clean or replace air filter.
	Thermostat adjustments or location.	Check thermostat heat anticipator setting against measured amperage draw. Increase heat anticipator setting if necessary. If the thermostat is being influenced by drafts, sunlight, duct work, etc., relocate to more suitable location.
	Insufficient airflow.	Check all dampers. Open closed dampers including registers in unused rooms. Check system temperature rise. If temperature rise is too high, speed up blower fan.
	Defective high limit control.	Test high limit function of all limit switches. Use a duct thermometer to assess accuracy of limit control. Check for obstructions to airflow around limit switch bi-metal elements. Replace control if necessary.
	Under-sized nozzle.	Check nozzle. If problem is not caused by air flow problems, use larger nozzle, if permitted by rating plate.
	Blower fan motor stopping intermittently on overload.	Check blower fan motor amperage draw. Check motor ventilation ports, clean if necessary. Replace motor if necessary.
	Burner motor stopping intermittently on overload.	Check burner motor. Replace if necessary.
Home does not heat evenly	Improper distribution of heat.	This is not likely to be a furnace problem. Balance duct system.
Supply air temperature too hot.	Airflow blocked or dirty air filter.	Clean or replace air filter.
	Insufficient airflow.	Check all dampers. Open closed dampers including registers in unused rooms. Check system temperature rise. If temperature rise is too high, speed up blower fan.
Supply air temperature too cool.	Excess airflow.	Check system temperature rise. Slow down blower fan if necessary.
	Excessive duct losses.	Check supply air ductwork. Seal leaky joints and seams. Insulate ductwork if necessary.
Supply air temperature too cool during first moments of furnace cycle.	Fan control "fan on" setting too low.	Increase differential between fan control "fan off" and "fan on" settings. (L4064B, L6064A fan / limit controls only, no adjustments available for L4064W fan / limit control). Register air deflectors may help.
	Excessive duct losses.	Check supply air ductwork. Seal leaky joints and seams. Insulate ductwork if necessary.

## PARTS LIST

### A. PARTS LISTING: LOWBOY MODEL: L-HO 170 - 225

Ref. No.	Description	Part Number
1	Left Side Panel Heating Compartment	29040L
2	Right Side Panel Heating Compartment	29040L
3	Left Side Panel Blower Compartment	29048L
4	Right Side Panel Blower Compartment	29047L
5	Upper Rear Panel Blower Compartment	29062L
6	Blower Partition Panel	29052L
7	Base Panel Assembly Heating Compartment	29043
8	Base Panel Assembly Blower Compartment	29056
9	Plenum Edge Panel Heating Compartment	29045L
10	Heat Exchanger Assembly	29224
11	Firepot Bracket Assembly	29225
12	Replacement Firepot	27000WP
13	Cleanout Pipe Cover (2 per unit)	29162
	Cleanout Cap Gasket (2 per unit)	240006333
14	Front Panel	29220R
	Logo Bezel	28479
	Logo Label	29687
15	Fan & Limit Control L4064W, 8" Insertion, Set @ 200° F	29041
16	Junction Box	21318
17	Fuse Holder	27089
18	Fuse, ABC-15	2200096
19	Wire Retainer Channel	8762B
20	Blower Access Door	29053L
	Door Handle – P2-41	28673
21	Front Panel Baffle	3022140A
22	Top Front Panel Baffle	29223
23	Oil Burner assembly Beckett AF81WF	29597
	Burner Motor 1/7 HP 3450 RPM PSC	29689
	Beckett Cleancut Oil Pump A2EA6520	29688
	Solid State Ignitor FRANCE 10SAY-04	29522
	Primary Combustion Control R7184B	29664
	Air Tube Combination AF81WF	29530
	Flame Retention Head (F16)	29531
	Nozzle 1.50/70° B (L-HO 170)	2101010
	Nozzle 1.65/70° B (L-HO 190)	2101011
	Nozzle 1.75/70° B (L-HO 200)	29288
	Nozzle 2.00/70° B (L-HO 225)	29289
24	Oil Burner Mounting Plate Assembly	1214B
	Inspection Door	8898A
	Inspection Door Gasket	2081055A
25	Pouch Gasket	2080175
26	Flue Pipe Assembly	1024B3
27	Flue Pipe Gasket (2 per unit)	2080181
28	Filter Rail Assembly (2 per unit)	29054
29	Top Filter Support	29063
30	Filter Support Front & Rear (2 per unit)	29055
31	Filter, 20" X 25" X1" Disposable (2 per unit) L-HO 170 & 190	2180012
31	Filter, 20" X 25" X1" Permanent (2 per unit) L-HO 200 & 225	2180024

## PARTS LISTING: LOWBOY MODEL: L-HO 170 - 225

Ref. No.	Description	Part Number
32	Draft Regulator	12401
33	Clean-out Gasket Retainer (2 per unit)	29161
	Cleanout Gasket (2 per unit)	29163
34	Blower Assembly, L-HO 170/190	8756B2
	Blower Housing and Wheel, G12	2040008
	Blower Motor, 3/4 hp Single Speed	28007
	Motor Pulley, 3 1/2 X 5/8 Adjustable With Keyway	19779
	Blower Pulley, 7 X 3/4	2240008
	Fan Belt, 4L430	2240022
	Blower Base Feet LH	8173B2
	Blower Base Feet RH	8173B1
34	Blower Assembly, L-HO 200/225	29217
	Blower Housing and Wheel, G12 With Ball Bearings	29222
	Blower Motor, 1 hp Single Speed	29218
	Motor Pulley 3 1/2 X 5/8 Adjustable With Keyway	19779
	Blower Pulley 6 X 3/4	2240006
	Fan Belt 4L410	2240020
	Blower Base Feet LH	8173B2
	Blower Base Feet RH	8173B1

# MODEL LHO-190 DIAGRAM

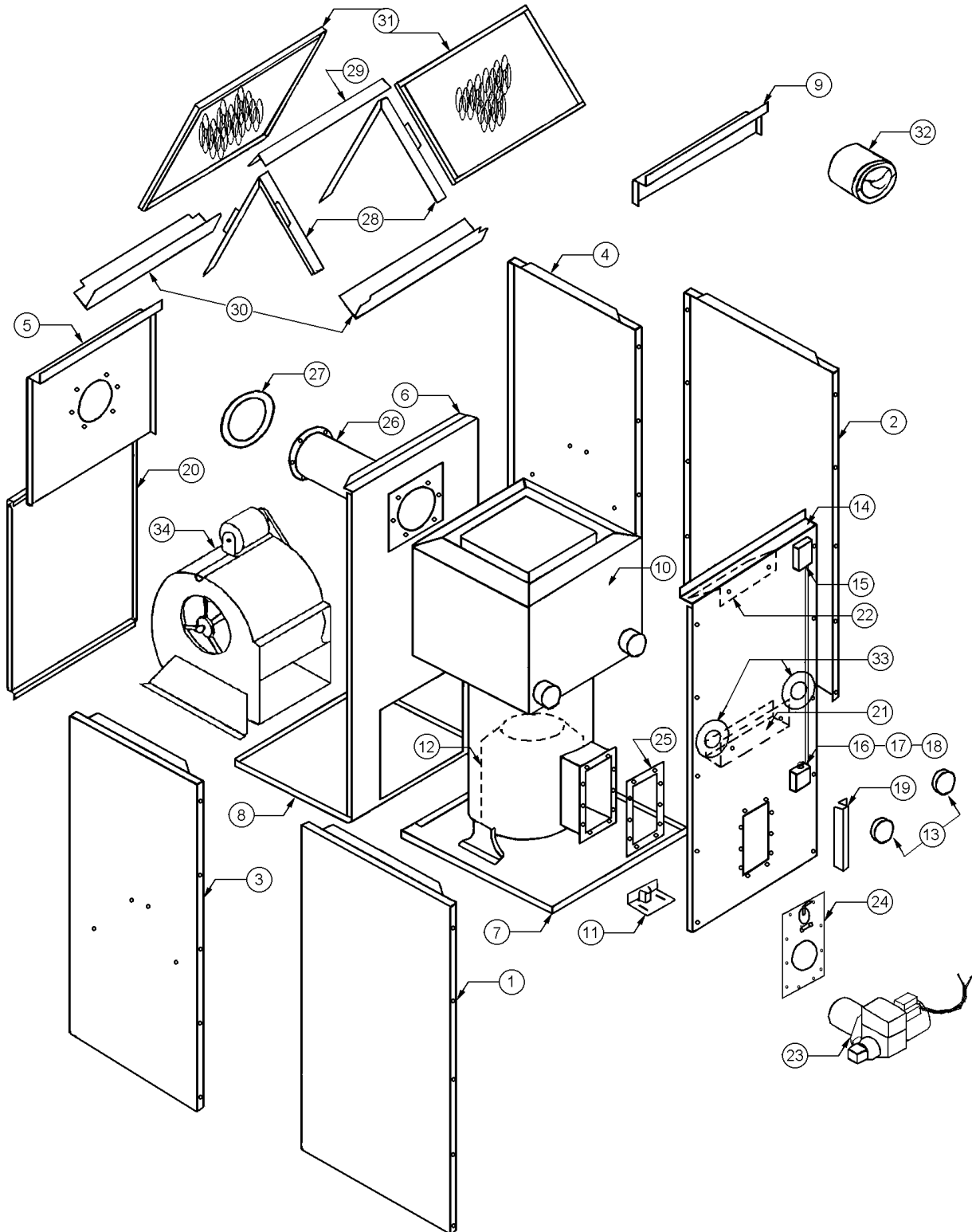

## PARTS LISTING: LOWBOY MODEL: L-HO-145DA4, 145DA5

Ref. No.	Description	L-HO-145DA4	L-HO-145DA5
1	Left Side Panel Assembly	28423L	28423L
2	Right Side Panel Assembly	28422L	28422L
3	Upper Rear Panel	26048L	26048L
4	Blower Division Panel Assembly	28468	29107
5	Base Panel Assembly	28459	28459
6	Inner Front Panel	28425	28425
7	Blower Access Door	26586L	26586L
	Door Handle – P2-41	28673	28673
8	Front Door Panel	29386R	29386R
	Logo Bezel	28479	28479
	Logo Label	29687	29687
9	Top Front Panel	26017L	26017L
10	Heat Exchanger Assembly	26098	26098
11	Flue Pipe Assembly	20597	20597
12	Firepot Bracket Assembly	4141185A	4141185A
13	Replacement Combustion Chamber Kit	8823B1	8823B1
14	Top Front Baffle	21485	21485
15	Inner Front Baffle	21425	21425
16	Right Side Panel Baffle	21344	21344
17	Oil Burner Mounting Plate Assembly	1214B	1214B
	Inspection Door Gasket	2081055A	2081055A
18	Pouch Gasket	2080175	2080175
19	Flue Pipe Gasket (2 per unit)	21994	21994
20	Cleanout Pipe Cover (2 per unit)	29162	29162
	Cleanout Cap Gasket (2 per unit)	240006333	240006333
21	Clean-out Gasket Retainer (2 per unit)	29161	29161
	Cleanout Gasket (2 per unit)	29163	29163
22	Air Filter – 20 x 25 x 1 (Permanent)	2180024	2180024
23	Junction Box	21318	21318
24	Wire Harness Blower Direct drive	27273	27275
25	Wire Harness Fan & Limit	26590	26838
26	Fan Centre	27740	26857
	27740 Replacement Relay 9400-04Q1999	27767	-----
	26857 Replacement Relay R8228B1012	-----	26854
27	Fan & Limit Control L6064A 11 ½", 230° F	21482	21482
	Fuse ABC 15 Amp Slow Blow	2200096	2200096
	Fuse Holder HKP-HH BCL	27089	27089
28	Draft Regulator 6"	12240	12240
29	Fan & Limit Support / Insulation Retainer	26973	26973
30	Side Panel Insulation Retainer (2 per unit)	26047	26047
31	Beckett Oil Burner AF65YB	29594	29594
	Burner Motor 1/7 HP 3450 RPM PSC	29689	29689
	Beckett Clean-cut Oil Pump A2EA6520	29688	29688
	Solid State Ignitor FRANCE 10SAY-01	29522	29522
	Primary Combustion Control R7184B	29664	29664
	Air Tube Combination AF65YB	20877	20877
	Flame Retention Head (F6)	12646	12646
	Nozzle, 1.10/70°A (L-HO-130 only)	2100101	2100101
	Nozzle, 1.20 / 60°A (L-HO-145 only)	21460	21460

**PARTS LISTING: LOWBOY MODEL: L-HO-145RDA4, 145RDA5**

Ref. No.	Description	L-HO-145RDA4	L-HO-145RDA5
32	Blower Assembly, Complete, Direct Drive, ½ hp 145RDA4	20643	-----
	Blower Housing and Wheel, G-10 DD	15011	-----
	Blower Wheel, G-10 DD	26430	-----
	Blower Motor, ½ hp, 4-Speed	26088	-----
	Motor Mounting Band – TR6884B	17811	-----
	Motor Mount Arms – 10-10 DD Blower (3 per unit)	26251	-----
	Motor Run Capacitor, 10 mfd @ 370 vac	27743	-----
	Capacitor Strap	27760	-----
	Capacitor Insulator	27769	-----
	Blower Base Feet LH	28643	-----
	Blower Base Feet RH	28642	-----
32	Blower Assembly, Complete, Direct Drive, 1 hp 145RDA5	-----	26812
	Blower Housing and Wheel, DCT1220-1104 DD	-----	26855
	Blower Wheel, 12-11 DD	-----	26653
	Blower Motor, 1 hp 3 Speed	-----	26826
	Motor Mounting Band – TR6884B	-----	17811
	Motor Mount Arms – 12-11 DD Blower (3 per unit)	-----	17812
	Motor Run Capacitor, 20 mfd @ 370 vac	-----	27745
	Capacitor Strap	-----	27761
	Capacitor Insulator	-----	27768
	Blower Base Feet LH & RH	-----	26012
	Terminal Block #EE8-201	-----	26833



# MODEL L-HO-145RDA DIAGRAM

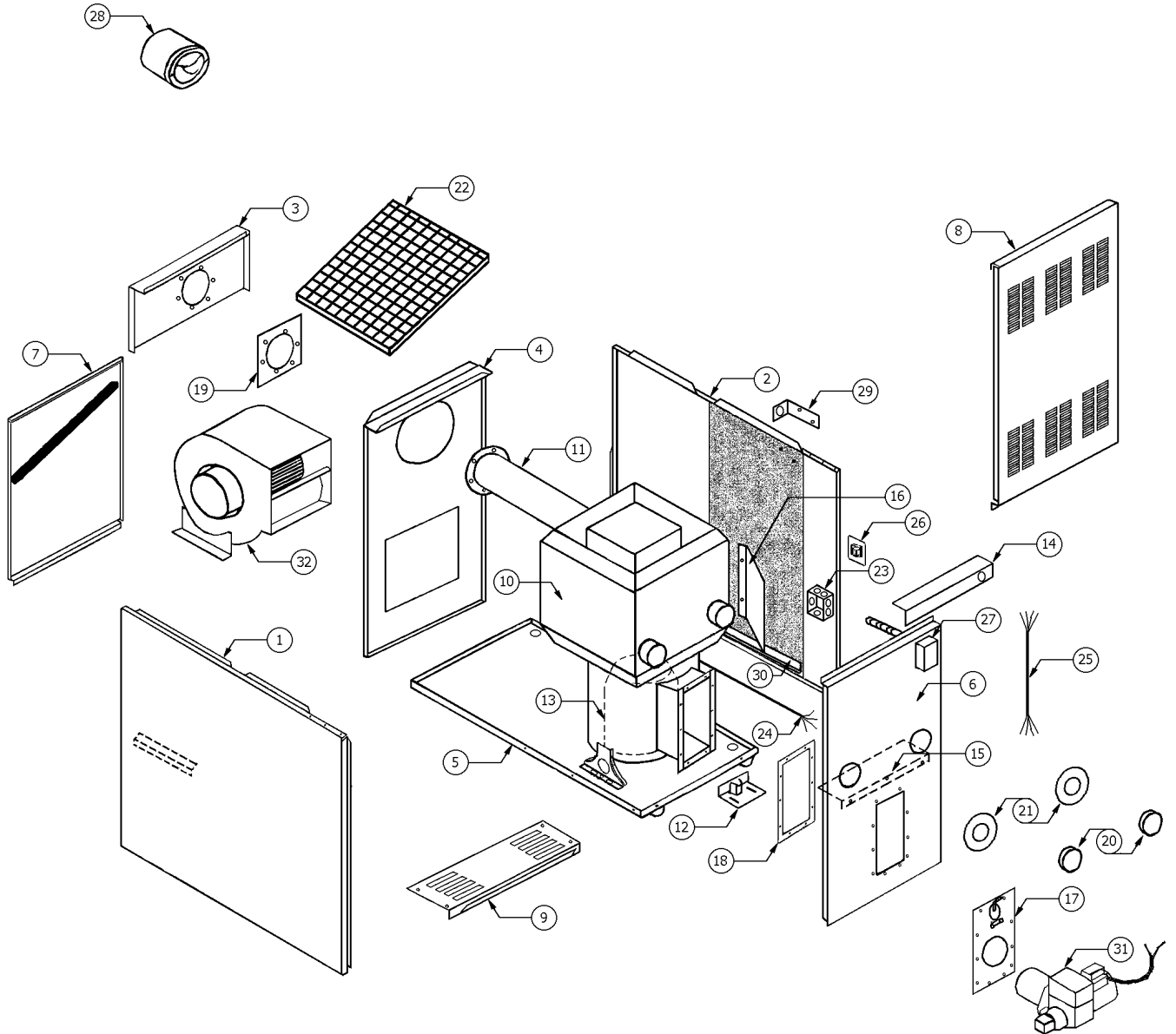

**HOME OWNER'S REFERENCE TABLE:**

**Installation Contractor:**

Model No.	
Serial No.	
Date Installed	
Contractor	
Contact	
Address	
Postal Code	
Telephone No.	
After Hours No.	

**Service Contractor if different from Installation Contractor:**

Service Tech.	
Telephone No.	
After Hours No.	

**Fuel Supplier:**

Oil Supplier	
Contact	
Telephone No.	
After Hours No.	

**Oneida Royal Division**

2201 Dwyer Avenue, Utica, NY 13504-4729

315-797-1310

[www.uticaboilers.com](http://www.uticaboilers.com)



**ECR** International