

INSTALLATION MANUAL AND OPERATING INSTRUCTIONS

PF SERIES CAST IRON PRESSURE-FIRED WET BASE HOT WATER BOILERS

ULTIMATE[®]



ULTIMATE BOILERS
85 Middle Rd.
Dunkirk, NY 14048
www.ecrinternational.com

 **An ECR International Brand**
An ISO 9001-2000 Certified Company



P/N 14683825, Rev. 2.1 [11/06]

INSTALLATION MANUAL AND OPERATING INSTRUCTIONS

P/N# 14683825, Rev. 2.1 [11/06] • Printed in USA • Made In USA

TABLE OF CONTENTS

Boiler Ratings and Capacities	4
Burner Setups	6
Optional Direct Exhaust System.....	9
Rules for Safe Installation and Operation.....	10
Indoor Boiler Assembly.....	12
Jacket Assembly (Indoor Boilers).....	13
System Near Boiler Piping (Indoor Boilers).....	14
Burner Wiring	16
Multi-Zone Wiring and Piping	17
Weatherproof (Outdoor) Boiler Installation.....	26
Normal Sequence of Operation.....	31
Typical Vent Safety Switch Installation.....	33
Maintenance.....	34
Service Hints and Troubleshooting.....	36
Repair Parts	37

KEEP THIS MANUAL NEAR BOILER
RETAIN FOR FUTURE REFERENCE

SAFETY SYMBOLS & WARNINGS

The following defined symbols are used throughout this manual to notify the reader of potential hazards of varying risk levels.

DANGER

Indicates an imminently hazardous situation which, if not avoided, **WILL** result in death or serious injury.

WARNING

Indicates a potentially hazardous situation which, if not avoided, **COULD** result in death or serious injury.

CAUTION

Indicates a potential hazardous situation which, if not avoided, **MAY** result in minor or moderate injury. It may also be used to alert against unsafe practices.

IMPORTANT: Read the following instructions **COMPLETELY** before installing!!

WARNING

Keep boiler area clear and free from combustible materials, gasoline and other flammable vapors and liquids.

Do not obstruct air openings to the boiler room.

Modification, substitution, or elimination of factory equipped, supplied, or specified components may result in property damage, personal injury or the loss of life.

TO THE INSTALLER: Leave all instructions with the boiler for future reference.



US

Tested For 100 LBS.
ASME
Working Pressure

INDOOR BOILER RATINGS AND CAPACITIES

Figure #1

INDOOR BOILER DIMENSIONS

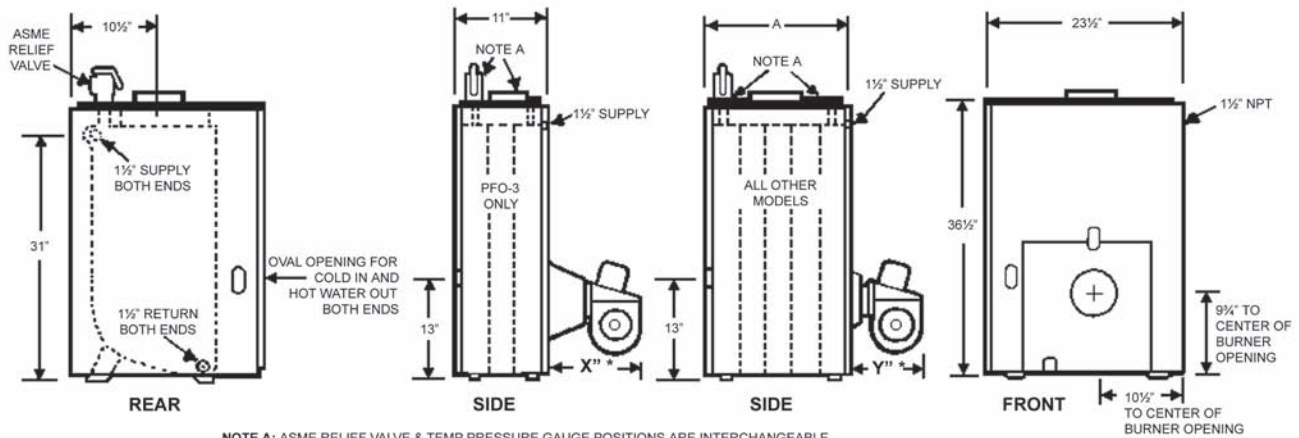

BURNER TYPE	AFG OIL	CF375 OIL	AFG W/AIR INTAKE BOOT	CF375 W/AIR INTAKE BOOT	RIELLO 40 SERIES OIL
X	11 1/2"	14"	18"	19 1/2"	16 7/8"
Y	8 1/2"	11"	15"	13 1/2"	13 7/16"

INDOOR OIL-FIRED HOT WATER BOILERS

WITH TANKLESS COIL

MODEL	RECOMMENDED FIRING RATES GPH		HEATING CAPACITY MBH ⁽¹⁾	NET I=B=R RATING MBH ⁽²⁾	ANNUAL FUEL UTILIZATION EFFICIENCY % ⁽³⁾	STEADY STATE EFFICIENCY %	NO. SEC.	FLUE SIZE ⁽⁴⁾	"A" DIM. LENGTH
PFO-3T	Min.	.50	62	54	87.6	88.40	3	5"	11"
	Max.	1.10	129	112	82.9	83.77			
PFO-4T	Min.	.65	80	70	87.5	88.35	4	6"	14 1/4"
	Max.	1.45	169	147	83.3	84.24			
PFO-5T	Min.	.80	99	86	87.5	88.31	5	6"	17 1/2"
	Max.	1.75	208	182	83.8	84.72			
PFO-6T	Min.	.95	117	102	87.5	88.26	6	7"	24"
	Max.	2.10	250	217	84.3	85.20			
PFO-8T	Min.	1.25	154	134	87.4	88.15	8	8"	30 1/2"
	Max.	2.75	324	282	...(5)	...(5)			

WITHOUT TANKLESS COIL

MODEL	RECOMMENDED FIRING RATES GPH		HEATING CAPACITY MBH ⁽¹⁾	NET I=B=R RATING MBH ⁽²⁾	ANNUAL FUEL UTILIZATION EFFICIENCY % ⁽³⁾	STEADY STATE EFFICIENCY %	NO. SEC.	FLUE SIZE ⁽⁴⁾	"A" DIM. LENGTH
PFO-3	Min.	.45	56	48	87.5	88.22	3	5"	11"
	Max.	.90	105	91	82.8	83.19			
PFO-4	Min.	.60	74	64	87.5	88.23	4	6"	14 1/4"
	Max.	1.35	159	138	83.3	83.91			
PFO-5	Min.	.75	93	81	87.5	88.23	5	6"	17 1/2"
	Max.	1.70	199	173	83.9	84.63			
PFO-7	Min.	1.05	130	113	87.6	88.24	7	7"	24"
	Max.	2.35	276	240	...(5)	...(5)			
PFO-9	Min.	1.35	167	146	87.6	88.26	9	8"	30 1/2"
	Max.	3.00	353	307	...(5)	...(5)			

Firing rates of 2.00 gph or less use a Beckett Model AFG oil burner. Firing rates over 2.00 gph use a Beckett Model CF375 oil burner. Optional Riello 40 Series oil burners also available.

OUTDOOR BOILER RATINGS AND CAPACITIES

Figure #2

WEATHERPROOF BOILER DIMENSIONS

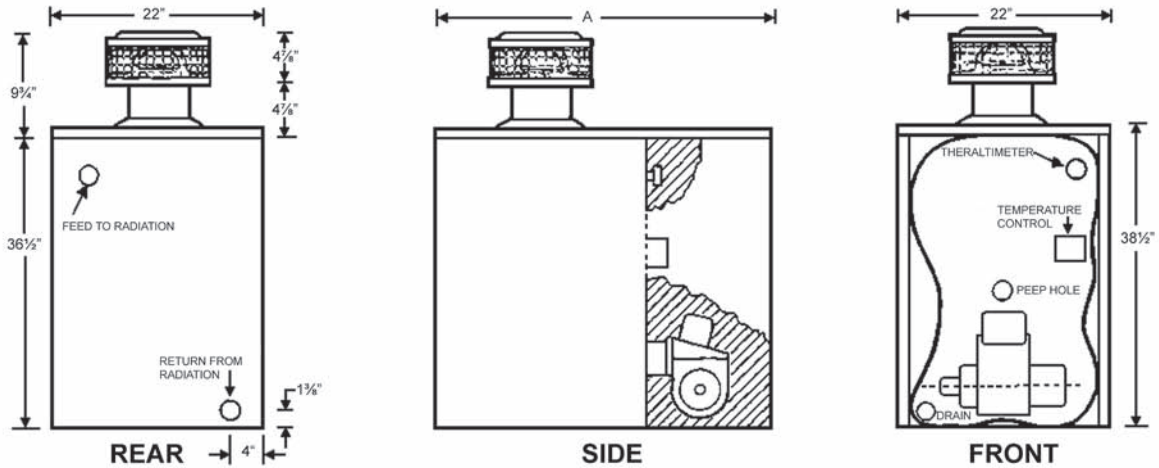

WEATHERPROOF OIL BOILERS

SPACE HEATERS WITHOUT TANKLESS COIL

MODEL	RECOMMENDED FIRING RATES GPH		HEATING CAPACITY MBH ⁽¹⁾	NET I=B=R RATING MBH ⁽²⁾	ANNUAL FUEL UTILIZATION EFFICIENCY % ⁽³⁾	STEADY STATE EFFICIENCY %	NO. SEC.	MULTI PASS COIL	"A" DIM. LENGTH
PFO-4W	Min.	.60	71	61	82.9	88.23	4	Less	28 ¹ / ₈ "
	Max.	1.35	151	131	78.6	83.19			
PFO-7W	Min.	1.05	124	107	82.9	88.24	7	Less	37 ¹ / ₈ "
	Max.	2.35	276	240	-- ⁽⁴⁾	-- ⁽⁴⁾			
PFO-9W	Min.	1.35	159	138	82.5	88.26	9	Less	44 ³ / ₈ "
	Max.	3.00	309	268	-- ⁽⁴⁾	-- ⁽⁴⁾			

IMPORTANT: ANTIFREEZE ADDED TO WEATHERPROOF BOILERS MUST BE NON-TOXIC!!

(1) D.O.E. Heating capacity is indicated in thousands of Btu per hour. Use of antifreeze in any boiler can reduce capacity, net output and efficiency by a significant amount.

(2) Net ratings are indicated in thousands of Btu per hour based on a piping and pickup allowance of 1.15.

(3) Annual Fuel Utilization Efficiency based on tests performed under U.S. Department of Energy standards and reported to the Federal Trade Commission.

(4) Capacity greater than that requiring testing under F.T.C. regulations. Firing rates of 2.00 gph or less use a Beckett Model AFG oil burner. Firing rates over 2.00 gph use a Beckett Model CF375 oil burner.

BURNER SETUPS

CHIMNEY VENT SUGGESTED BECKETT BURNER SETUPS

Note: These settings are intended for initial start up only. Final adjustments must be made using combustion test instruments.

Boiler Size	Firing Rate	Beckett Burner	Burner Part Number	Nozzle Mfg.	Nozzle	Pump Pressure	Head	Drawer Assy Adj.	Low Fire Baffle	Air Shutter	Air Band
PFO-3	0.65	AFG	14619201	Delavan	.60 X 80 A	140	F0	Fixed	Yes	10.0	1.0
	0.75	AFG	14619201	Delavan	.65 X 70 A	140	F0	Fixed	No	10.0	0.0
	0.90	AFG	14619201	Delavan	.75 X 80 B	140	F3	Fixed	No	10.0	0.0
PFO-3T	0.65	AFG	14619201	Delavan	.60 X 80 A	140	F0	Fixed	Yes	10.0	2.0
	0.85	AFG	14619201	Delavan	.75 X 80 A	140	F3	Fixed	No	10.0	1.0
	1.10	AFG	14619201	Delavan	.90 X 80 B	140	F3	Fixed	No	10.0	1.0
PFO-3T2	1.10	AFG	14619201	Delavan	.90 X 80 B	140	F3	Fixed	No	10.0	1.0
PFO-4	0.65	AFG	14619201	Delavan	.60 X 80 A	140	F0	Fixed	Yes	10.0	1.0
	1.00	AFG	14619201	Delavan	.75 X 80 A	140	F3	Fixed	No	10.0	0.0
	1.35	AFG	14619201	Delavan	1.20 X 80 B	140	F6	Fixed	No	10.0	2.0
PFO-4T	0.65	AFG	14619201	Delavan	.60 X 80 B	140	F0	Fixed	Yes	10.0	1.0
	0.95	AFG	14619201	Delavan	.85 X 80 B	140	F3	Fixed	No	10.0	1.0
	1.45	AFG	14619201	Delavan	1.25 X 80 B	140	F6	Fixed	No	10.0	2.0
PFO-5	0.75	AFG	14619201	Delavan	.65 X 80 A	140	F3	Fixed	Yes	10.0	1.0
	1.10	AFG	14619201	Delavan	1.00 X 80 A	140	F6	Fixed	No	10.0	1.0
	1.70	AFG	14619201	Delavan	1.50 X 80 A	140	F12	Fixed	No	10.0	3.0
PFO-5T	0.80	AFG	14619201	Delavan	.65 X 70 A	140	F3	Fixed	Yes	10.0	0.0
	1.50	AFG	14619201	Delavan	1.00 X 70 A	140	F6	Fixed	No	10.0	1.0
	1.75	AFG	14619201	Delavan	1.50 X 70 A	140	F12	Fixed	No	10.0	3.0
PFO-6T	0.95	AFG	14619201	Delavan	.85 X 80 B	140	F3	Fixed	No	10.0	2.0
	1.45	AFG	14619201	Delavan	1.20 X 80 B	140	F6	Fixed	No	10.0	3.0
	2.10	CF375	240006445	Delavan	1.75 X 60 B	140	CF56KZ SL1	0	No	10.0	0.0
PFO-6T2	2.10	CF375	240006445	Delavan	1.75 X 60 B	140	CF56KZ SL1	0	No	10.0	0.0
PFO-7	1.00	AFG	14619201	Delavan	.90 X 80 B	140	F3	Fixed	No	10.0	0.0
	1.60	AFG	14619201	Delavan	1.35 X 80 B	140	F12	Fixed	No	10.0	1.0
	2.35	CF375	240006445	Delavan	2.00 X 60 B	140	CF56KZ SL1	0	No	10.0	2.5
PFO-7TT2	2.00	CF375	240006445	Delavan	1.65 X 60 B	140	CF56KZ SL1	0	No	5.0	1.0
PFO-8T	1.25	AFG	14619201	Delavan	1.00 X 70 A	140	F6	Fixed	No	10.0	6.0
	1.90	CF375	240006445	Delavan	1.50 X 60 B	140	CF56KZ SL1	1	No	10.0	0.0
	2.75	CF375	240006445	Delavan	2.25 X 60 B	140	CF56KZ SL1	1	No	10.0	3.0
PFO-8T2	2.00	CF375	240006445	Delavan	1.65 X 60 B	140	CF56KZ SL1	1	No	5.0	1.0
	2.75	CF375	240006445	Delavan	2.25 X 60 B	140	CF56KZ SL1	1	No	10.0	3.0
PFO-9	1.35	AFG	14619201	Delavan	1.20 X 70 A	140	F6	Fixed	No	10.0	2.0
	2.00	CF375	240006445	Delavan	1.65 X 45 B	140	CF56KZ SL1	0	No	6.5	0.0
	3.00	CF375	240006445	Delavan	2.50 X 60 B	140	CF56KZ SL1	3	No	10.0	4.0

1. All burners fired at an over fire pressure of +0.02" w.c.

2. Burner insertion depth is 4 5/8"

3. Nozzle is NOT factory installed and must be installed in the field.

4. All F Heads are fixed with a "Z" dimension of 1 1/8". See Beckett burner manual for proper "Z" dimension setup.

BURNER SETUPS

CHIMNEY VENT SUGGESTED RIELLO BURNER SETUPS

Note: These settings are intended for initial start up only. Final adjustments must be made using combustion test instruments.

Boiler Size	Firing Rate	Riello Burner	Burner Part Number	Nozzle Mfg.	Nozzle	Pump Pressure	Turbulator Setting	Air Gate Setting
PFO-3	0.90	F5	1050006	Delavan	.75 X 60 W	150	3.0	5
PFO-3T	0.95	F5	1050006	Delavan	.75 X 60 W	160	3.0	4.5
	1.10	F5	1050006	Delavan	.85 X 60 W	170	2.0	3.1
PFO-4	1.00	F5	1050006	Delavan	.85 X 60 W	150	2.0	3.25
	1.35	F5	1050006	Delavan	1.10 X 60 W	150	3.5	4.5
PFO-4T	1.45	F5	1050006	Delavan	1.20 X 60 A	150	4.0	4.3
PFO-5	0.75	F5	1050006	Delavan	.60 X 60 W	155	0.5	2.25
	1.10	F5	1050006	Delavan	.85 X 60 W	170	2.0	3
	1.70	F10	14619011	Delavan	1.35 X 60 W	160	1.5	3
PFO-5T	0.80	F5	1050006	Delavan	.60 X 60 A	175	1.0	2.3
	1.50	F5	1050006	Delavan	1.25 X 60 A	150	4.0	5.5
	1.75	F10	14619011	Delavan	1.35 X 60 A	170	1.5	3.2
PFO-6T	0.95	F5	1050006	Delavan	.75 X 60 W	175	1.5	2.8
	1.45	F5	1050006	Delavan	1.20 X 60 W	170	3.5	5
	2.10	F10	14619011	Delavan	1.75 X 60 W	170	2.5	4.5
PFO-7	1.00	F5	1050006	Delavan	.85 X 60 W	150	2.0	3.2
	1.60	F10	14619011	Delavan	1.35 X 60 W	175	3.0	1.5
	2.35	F10	14619011	Delavan	2.00 X 60 W	160	4.0	3.5
PFO-8T	1.25	F5	1050006	Delavan	1.00 X 60 W	175	2.5	4
	1.90	F10	14619011	Delavan	1.50 X 45 W	175	2.0	3.4
	2.75	F10	14619011	Delavan	2.25 X 45 W	175	5.0	6
PFO-9	1.35	F5	1050006	Delavan	1.10 X 60 W	165	3.5	3.8
	2.00	F10	14619011	Delavan	1.65 X 60 W	165	2.5	3.4
	3.00	F10	14619011	Delavan	2.50 X 60 B	150	5.0	7.8

1. All burners fired at an over fire pressure of +0.02" w.c.
2. Burner insertion depth is 4 5/8"
3. Nozzle is NOT factory installed and must be installed in the field.

BURNER SETUPS

SIDE WALL VENTED (FDVS) SUGGESTED BECKETT BURNERS SETUPS

Note: These settings are intended for initial start up only. Final adjustments must be made using combustion test instruments.

Boiler Size	Firing Rate	Beckett Burner	Burner Part Number	Nozzle Mfg.	Nozzle Size	Pump Pressure	Head / Choke	Drawer Assy Adj	Low Fire Baffle	Air Shutter	Vent Kit Part Number Less Burner	Vent Kit Part Number with Burner
PFO-3	0.65	AFG	14619202	Delavan	.60 X 80 A	140	F0	Fixed	Yes	125	550001447	550001450
	0.75	AFG	14619202	Delavan	.65 X 70 A	140	F0	Fixed	No	110	550001447	550001450
	0.90	AFG	14619202	Delavan	.75 X 80 B	140	F3	Fixed	No	55	550001447	550001450
PFO-3T	0.65	AFG	14619202	Delavan	.60 X 80 A	140	F0	Fixed	Yes	125	550001447	550001450
	0.85	AFG	14619202	Delavan	.75 X 80 A	140	F3	Fixed	No	110	550001447	550001450
	1.10	AFG	14619202	Delavan	.90 X 80 B	140	F3	Fixed	No	55	550001447	550001450
PFO-4	0.65	AFG	14619202	Delavan	.60 X 80 A	140	F0	Fixed	Yes	80	550001448	550001451
	1.00	AFG	14619202	Delavan	.75 X 80 A	140	F3	Fixed	No	45	550001448	550001451
	1.35	AFG	14619202	Delavan	1.20 X 80 B	140	F6	Fixed	No	130	550001448	550001451
PFO-4T	0.65	AFG	14619202	Delavan	.60 X 80 B	140	F0	Fixed	Yes	80	550001448	550001451
	0.95	AFG	14619202	Delavan	.85 X 80 B	140	F3	Fixed	No	45	550001448	550001451
	1.45	AFG	14619202	Delavan	1.25 X 80 B	140	F6	Fixed	No	130	550001448	550001451
PFO-5	0.75	AFG	14619202	Delavan	.65 X 80 A	140	F3	Fixed	Yes	75	550001448	550001451
	1.10	AFG	14619202	Delavan	1.00 X 80 A	140	F6	Fixed	No	155	550001448	550001451
	1.70	AFG	14619202	Delavan	1.50 X 80 A	140	F12	Fixed	No	222	550001448	550001451
PFO-5T	0.80	AFG	14619202	Delavan	.65 X 70 A	140	F3	Fixed	Yes	75	550001448	550001451
	1.50	AFG	14619202	Delavan	1.00 X 70 A	140	F6		No	155	550001448	550001451
	1.75	AFG	14619202	Delavan	1.50 X 70 A	140	F12	Fixed	No	222	550001448	550001451
PFO-6T	0.95	AFG	14619202	Delavan	.85 X 80 B	140	F3	Fixed	No	50	550001448	550001451
	1.45	AFG	14619202	Delavan	1.20 X 80 B	140	F6	Fixed	No	110	550001448	550001451
	2.10	CF375	240006433	Delavan	1.75 X 45 B	140	CF56KZ SL1	0	No	60	550001448	550001449
PFO-7	1.00	AFG	14619202	Delavan	.90 X 80 B	140	F3	Fixed	No	100	550001448	550001451
	1.60	AFG	14619202	Delavan	1.35 X 80 B	140	F12	Fixed	No	190	550001448	550001451
	2.35	CF375	240006433	Delavan	2.00 x 45 B	140	CF56KZ SL1	0	No	170	550001448	550001449
PFO-8T	1.25	AFG	14619202	Delavan	1.00 X 70 A	140	F6	Fixed	No	70	550001448	550001451
	1.90*	CF375	240006433	Delavan	1.50 X 45 B	140	CF56KY V1	1	No	45	550001448	550001449
	2.75	CF375	240006433	Delavan	2.25 X 45 B	140	CF56KZ SL1	1	No	140	550001448	550001449
PFO-9	1.35	AFG	14619202	Delavan	1.20 X 70 A	140	F6	Fixed	No	127	550001448	550001451
	2.00	CF375	240006433	Delavan	1.65 X 45 B	140	CF56KZ SL1	0	No	55	550001448	550001449
	3.00	CF375	240006433	Delavan	2.50 X 45 B	140	CF56KZ SL1	3	No	120	550001448	550001449

1. All burners fired at an over fire pressure of +0.02" w.c.

2. Burner insertion depth is 4 5/8"

3. Nozzles are NOT factory installed and must be installed in the field.

4. All F Heads are fixed with a "Z" dimension of 1 1/8". See Beckett burner manual for proper "Z" dimension setup.

* NOTE: The burner for the 8 section FDVS 1.90 GPH input needs a static disk change, see the Kit #550001620 for details.

OPTIONAL DIRECT EXHAUST SYSTEM

The optional FDVS is to be used in conjunction with the PF boiler for indoor installations requiring through the wall venting. The FDVS is designed as an integral part of the PF boiler, eliminating the need for a power venter.

Boiler	Kit	Duct Dia.	Wall Opening
3 sections	FDVS 4	4"	6½"
4 to 9 sections	FDVS 6	6"	8½"

Oil boiler FDVS kits include an oil burner with adjustable post purge timer and solenoid valve. For through the wall venting, this post purge burner must be used in place of the standard burner that is furnished with the boiler.

SELECTION OF BOILER SIZE

Selection of boiler size should be based upon "Net I=B+R Rating MBH being equal to or greater than the calculated heat loss of the building.

These boilers are low pressure sectional cast iron boilers constructed and hydrostatically tested for a maximum working pressure of 50 psi in accordance with A.S.M.E. (American Society of Mechanical Engineers) Section IV Standards for cast iron heating boilers. They are capacity rated in accordance with the code of the Hydronics Institute.

These boilers operate on #2 Heating Oil, Natural Gas, or Propane Gas, with the proper burner.

IMPORTANT

Standard indoor PF Series boilers are furnished as knockdown boilers and are shipped as four components (w/o FDVS) or five components (with FDVS) are shown below:

- basic boiler assembly
- boiler jacket
- accessory kit
- burner (without post purge)
- FDVS parts (include post purge oil burner for oil-fired burners)

Weatherproof (outdoor) PF Series boilers are furnished as knockdown boilers only and are shipped as five components as shown below:

- basic boiler assembly
- weatherproof boiler jacket
- exhaust cap, pipe, and weather collar
- accessory kit
- burner

On knockdown oil burners, the oil burner nozzle is not included. Correctly sized nozzle must be installed prior to startup.

Indoor oil-fired models PFO (3, 4, 5, 3T, 4T, 5T) without direct exhaust system are available as packaged boilers, in which case an oil burner nozzle for one of three specified firing rates will be factory installed in the oil burner.

RULES FOR SAFE INSTALLATION AND OPERATION

WARNING

Improper installation, adjustment, alteration, service, or maintenance can use property damage, personal injury, or loss of life.

All installations must conform to the requirements of the authority having jurisdiction. Such applicable requirements take precedence over the general instructions of this manual.

Where required, by the authority having jurisdiction, the installation must conform to the American Society of Mechanical Engineers Safety Code for Controls and Safety Devices for Automatically Fired Boilers, ANSI/ASME No. CSD-1. In Canada, all installations must be in accordance with the authorities having jurisdiction and CSA B139.

1. The installation must conform to the requirements of the authority having jurisdiction or, in absence of such requirements, to the latest revision of the National Fuel Gas Code, ANSI Z223-1. (Available from the American Gas Association, Pleasant Valley Rd., Cleveland, OH, 44134.) Reference should also be made to local gas utility regulations and other codes in effect in the area in which the installation is to be made.

2. Where required by the authority having jurisdiction, the installation must conform to American Society of Mechanical Engineers Safety Code for Controls and Safety Devices for Automatically Fired Boilers, ANSI/ASME No. CSD-1.

3. This boiler is classified as a Category I and III and vent installation shall be in accordance with Part 7 of the latest revision of the National Fuel Gas Code, ANSI Z223.1 or applicable provisions of the local building codes.

- Read the installation manual before beginning the installation. Failure to follow the rules for safe operation and the instructions can cause a malfunction of the boiler and result, serious bodily injury, and/or property damage.
- Check your local codes and utility requirements before installation. The installation must be in accordance with their directives, or, in their absence, follow NFPA Installation Codes and good industry practice.
- Before servicing, allow boiler to cool. Always shut off any electricity and oil to boiler when working on it. This will prevent any electrical shocks or burns.
- Inspect oil lines and connections for leaks.
- Be certain oil burner nozzle or gas orifice is size required. Over-firing will result in early failure of the boiler sections. This will cause dangerous operation.
- Never vent this boiler into an enclosed space. Always vent to the outside. Never vent to another room or inside a building.
- Be sure there is adequate air supply for complete combustion.
- Follow a regular service and maintenance schedule for efficient and safe operation.
- Keep boiler area clean and free of combustible material, gasoline, and other flammable vapors and liquids.
- Proper through-the-wall venting requires use of complete FDVS (oil-fired units only).
- Oil and gas burners are not do-it-yourself items. This boiler must be installed and serviced by qualified professionals using combustion test instruments.
- Be aware when piping the relief valve if the system pressure exceeds the safe limit of 30 lbs. per square inch, the relief valve will automatically open. Lifting of the relief valve can discharge large quantities of steam and hot water, which may damage the surroundings. Before installing the relief valve, read the manufacturer's instructions and the maintenance section of the manual on relief valves.

RULES FOR SAFE INSTALLATION AND OPERATION

- Frequent and mysterious lifting of the relief valve may be a sign of an improperly sized expansion tank. Installation and sizing of the expansion tank must consider the heating system's total water volume, temperature, boiler initial fill pressure, and system arrangement. For proper installation and maintenance follow the guidelines established by ECR and the manufacturer.
- Expansion tank performance and life expectancy can be hindered by overfilling the boiler. ECR recommends an initial fill pressure of 10 – 12 psig. For higher fill pressures, the expansion tank's air charge will need to match the fill pressure. Consult the manufacturer's guidelines for sizing and selection.
- Purging the heating system of air and gases during the boiler's initial commissioning is critical for proper circulation and quiet performance. Once the air and gases are purged, for boiler installations using float type vents, the air vents should be closed for normal operation. If air is heard or noticed by a loss of heat, purge the system and open the vents for a short period of time.

⚠ CAUTION ⚠

This boiler has been designed for residential installations. If used for commercial applications, all jurisdictional requirements must be met. This may require wiring and/or piping modifications. The manufacturer is not responsible for any changes to the original design.

DO NOT USE GASOLINE CRANKCASE DRAININGS OR ANY OIL CONTAINING GASOLINE.

BEFORE YOU START

Check to be sure you have the right size boiler before starting the installation. See rating and capacity tables on preceding pages. Check the rating plate on the right side of the boiler.

You must see that the boiler is supplied with the proper fuel, fresh air for combustion, and a suitable electrical supply. Also, the boiler must be connected to a suitable venting system and an adequate piping system. Finally, a thermostat, properly located, is needed for control of the heating system. If you have any doubts as to the various requirements, check with local authorities and obtain professional help where needed.

These installation instructions are vital to the proper and safe operation of the heating system. Take the time to be sure they are carefully followed.

⚠ CAUTION ⚠

Always keep the manual fuel supply valve shut off, if the burner is shut down for an extended period of time.

THE PUMP PRESSURE OF THE STANDARD BECKETT BURNER IS SET AT 140 PSI.

The output of the burner nozzle will be 18% greater than rated.

Rated Output (gph) at 100 psi (nozzle label)	Actual Output (gph) at 140 psi (approximate)
.40	.47
.50	.59
.60	.71
.65	.77
.75	.89
.85	1.01
1.00	1.18
1.10	1.30
1.20	1.42
1.25	1.48
1.35	1.60
1.50	1.77
1.65	1.95
1.75	2.07
2.00	2.37
2.25	2.66
2.50	2.96

INDOOR BOILER INSTALLATION

Figure #3

GENERAL REQUIREMENTS FOR A TYPICAL INSTALLATION

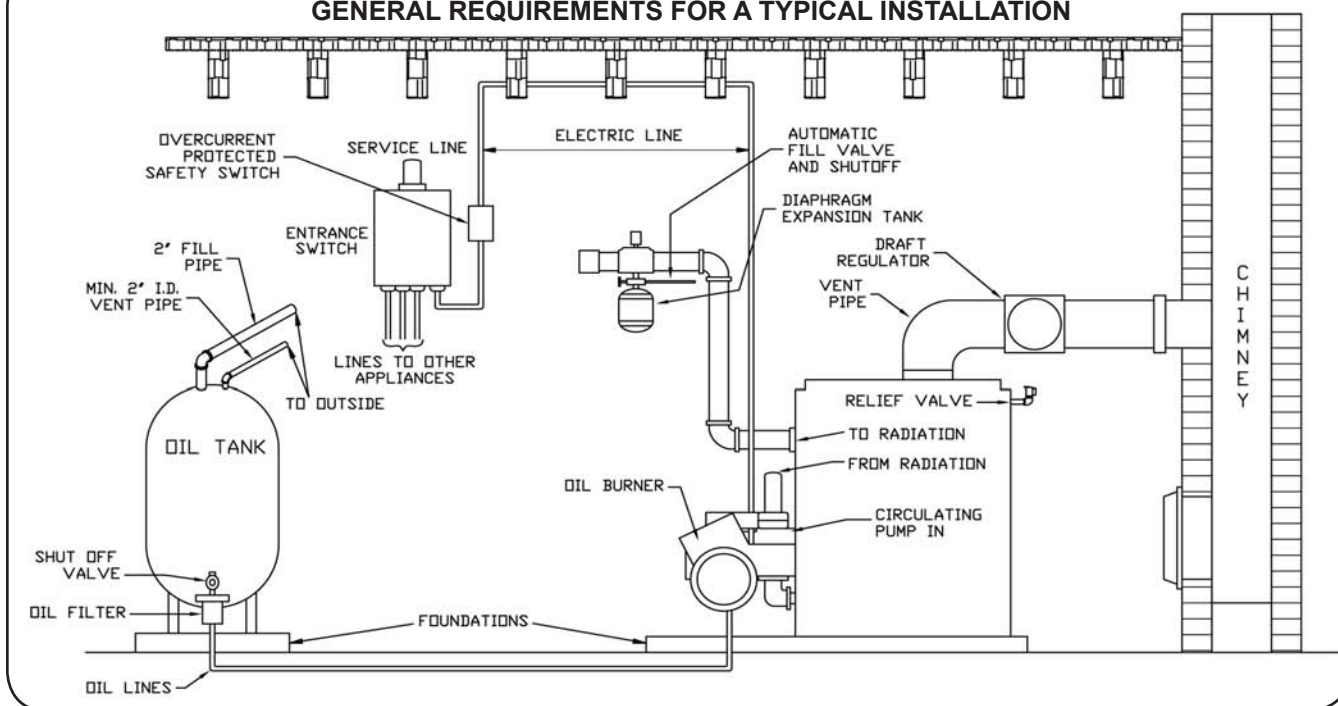
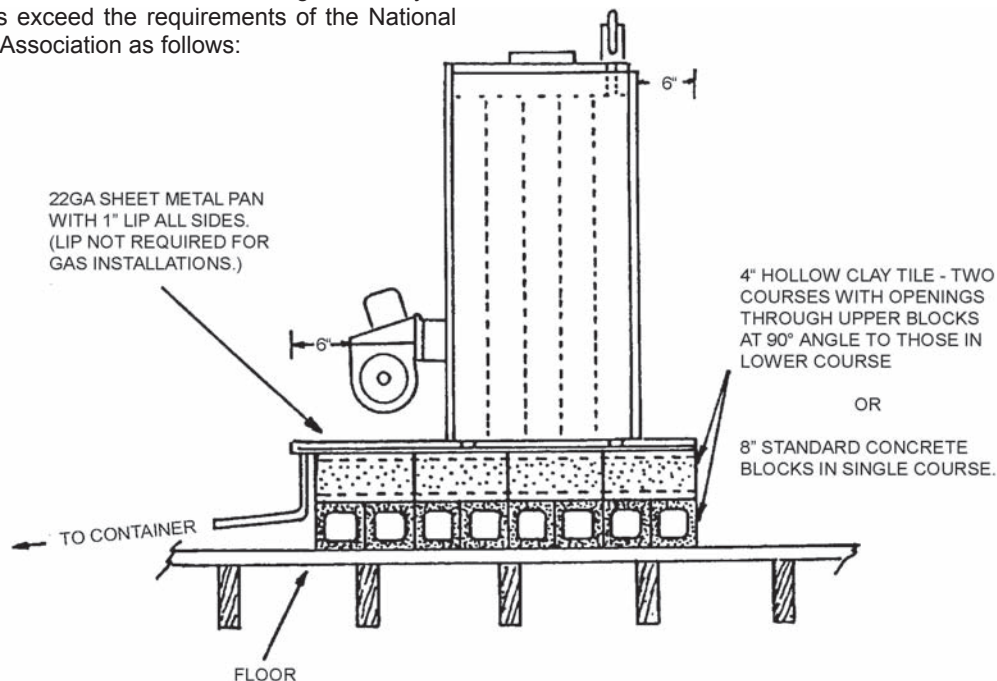

Figure #4

RECOMMENDED FIREPROOF BASE FOR INSTALLATION ON COMBUSTIBLE FLOORING

NOTE: The above recommendations in regard to clay or concrete blocks exceed the requirements of the National Fire Protection Association as follows:



N.F.P.A. 31 Section 4-4.1.5 Appliances may be placed on combustible floors, although not listed for such installation, provided the floor under the appliance is protected in accordance with the requirements of accepted building code practice. (A water-wall-type heating boiler operating

not in excess of 250° F for water boilers) may be placed on a combustible floor protected with hollow masonry not less than 4" (100mm) thick covered with sheet metal not less than 24 gauge. Such masonry shall be laid with ends unsealed and joints matched in such a way as to permit free circulation of air from side to side through the masonry.

LOCATING THE BOILER

NOTE: Please see the separate Venting Instruction for flue size limitation and other information on venting. For direct exhaust systems, the total run of horizontal flue pipe must not exceed 6' and the total run of vertical flue pipe must not exceed 10'.

1. Place boiler at a location as centralized to the piping system and as close to the chimney or vent terminal as possible to minimize condensation. At input rates up to 1.75 gph (245,000 Btu/hr), the supply and return from radiation may be piped on the same end of the boiler. At higher rates, it is recommended that the supply be piped from the rear of the boiler and the return be piped from the front of the boiler. Coordinate jacket installation with piping. See "Jacket Assembly Instructions" and "Piping Diagrams" in this manual for more information.

2. See **Figure #4** for installation on combustible flooring. If necessary, place metal shims beneath feet to ensure a level unit.
3. Accessibility clearances must take precedence over fire protection clearances. Allow at least 24" for servicing at the tankless and burner sides of the unit. Allow at least 18" at a side where passage is required for access to another side for servicing. A 6" clearance from combustible material on all sides and the top is recommended. 18" clearance is necessary between smoke pipe and nearest combustible material. See NFPA 31, latest revision, for safe methods to reduce clearances where necessary. NFPA publications are available at Battery Park, Quincy, MA 02269.

**CONSULT FIRE AUTHORITIES
FOR LOCAL REQUIREMENTS**

JACKET ASSEMBLY (Indoor Boilers)

Figure #5

JACKET ASSEMBLY (INDOOR BOILERS)

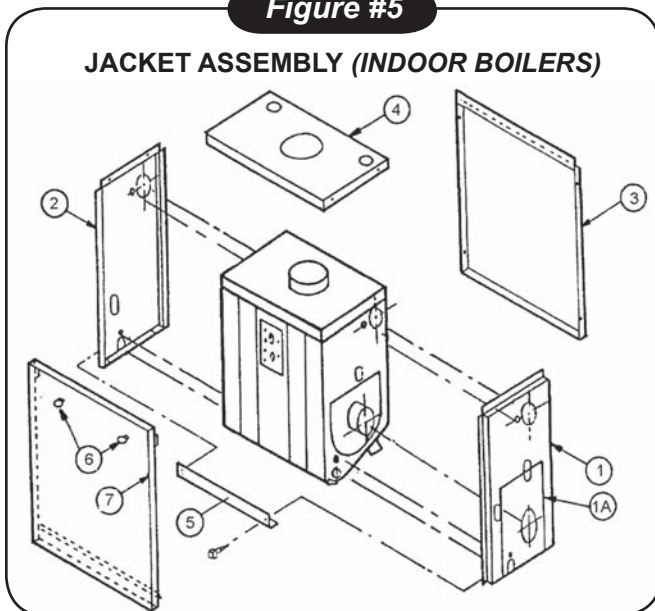

1. See **Figure #5** (above) for reference. Note that all sheet metal screws are #10 unless specified otherwise.
2. See hardware package in boiler accessory kit for stand-off bolts, studs, acorn nuts, washers, and 1/8" pipe plug. Note that the sight glass assembly is also found in the boiler accessory kit.
3. Screw double end stand-off bolts into castings next to upper supply and lower return tapplings

in both ends of the boiler. Screw three 5/16" studs finger-tight into burner mounting.

4. Hold panels 1 and 1A against burner end of boiler and insert necessary piping through jacket openings into boiler casting.
5. Screw acorn nuts onto stand-off bolts.
6. Screw 1" nipple and sight glass holder into hole above burner.
7. Screw the 1/8" plug into tapping on upper left of burner mounting.
8. Install panel 2 on opposite side of boiler in same manner as panel 1.
9. Install panel 3 by attaching it with four sheet metal screws to panels 1 and 2 (already in position).
10. Install temperature/pressure gauge into either of the two 3/4" tapplings on top of the casting. Using a 3/4" x 4 1/2" nipple, install relief valve in second top tapping. Install jacket top panel (#4) by attaching it with four sheet metal screws to the three jacket side panels already in position.

To permit easy disassembly of overflow pipe in order to raise jacket top panel for annual cleaning, screw hand tight a 3/4" nipple into the relief valve. Attach a 3/4" elbow to the nipple and an overflow

JACKET ASSEMBLY (Indoor Boilers) Continued

pipe to the elbow. (Nipple, elbow and overflow pipe not supplied.) Do not connect directly to a drain, but leave an air gap. No shutoff of any description shall be placed between the safety relief valve and the boiler, or on discharge pipes between such safety valves and the atmosphere. Installation of the safety relief valve shall conform to the ANSI/ASME Boiler and Pressure Vessel Code, Section IV. The manufacturer is not responsible for any water damage.

If preferred, one of the top tapings may be used for an air vent and the relief valve may

be installed in an upper 1½" side tapping of the casting with a bushing, nipple, and street elbow. Valve spindle must be vertical.

11. Install angle iron (#5) open edge up to panels 1 and 2 on the remaining exposed side of the boiler near floor level. Angle iron is attached with two sheet metal screws to the inside of the turned edges of panels 1 and 2.
12. Install knobs (#6) on door panel (#7) using #8 machine screws. Install door panel by resting lower edge inside angle iron (#5) and snapping top sides into place.

NEAR BOILER SYSTEM PIPING (Indoor Boilers)

1. Antifreeze added to boilers must be non-toxic, and must of a type specifically intended for use in closed hydronic heating systems. Under no circumstances should automotive antifreeze be used.
2. Use of antifreeze in any boiler may reduce capacity by 10% or more and increase fuel consumption. Tankless coil performance will fall as concentration of antifreeze is increased. See below for water volumes of boilers and piping.
3. Because antifreeze forms slush rather than hard ice, it is safe to protect only to 10 degrees above coldest temperature anticipated provided slush formed can move towards expansion tank.

BOILER WATER VOLUMES

Model	Gallons	Model	Gallons
PF-3	7	PF-3T	10
PF-4	9	PF-4T	12
PF-5	11	PF-5T	14
PF-7	15	PF-6T	16
PF-9	19	PF-8T	20

PIPING WATER VOLUMES

Divide total length of piping in feet by appropriate factor below to determine volume in gallons.

Pipe Size	Copper Pipe Factor	Steel Pipe Factor
½"	82.5	63.5
¾"	40.0	36.0
1"	23.3	22.2
1¼"	15.3	12.8
1½"	10.8	9.5
2"	6.2	5.8

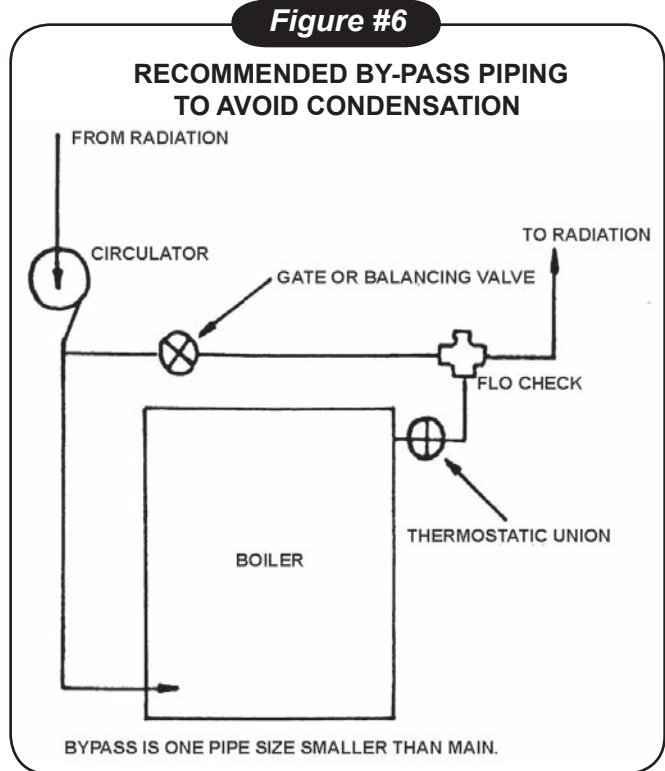

As efficiencies increase and slack temperatures decrease, it becomes increasingly important to keep boiler warm enough to discourage condensation. All steel and cast-iron boilers can rust badly if operated for extended periods at water temperatures below 140 and chimneys can be damaged as well.

The purpose of the by-pass shown in **Figure #6** (above) is to permit the boiler to warm up faster than the radiation system, thereby decreasing the potential for condensation in both boiler and chimney.

Figure #7

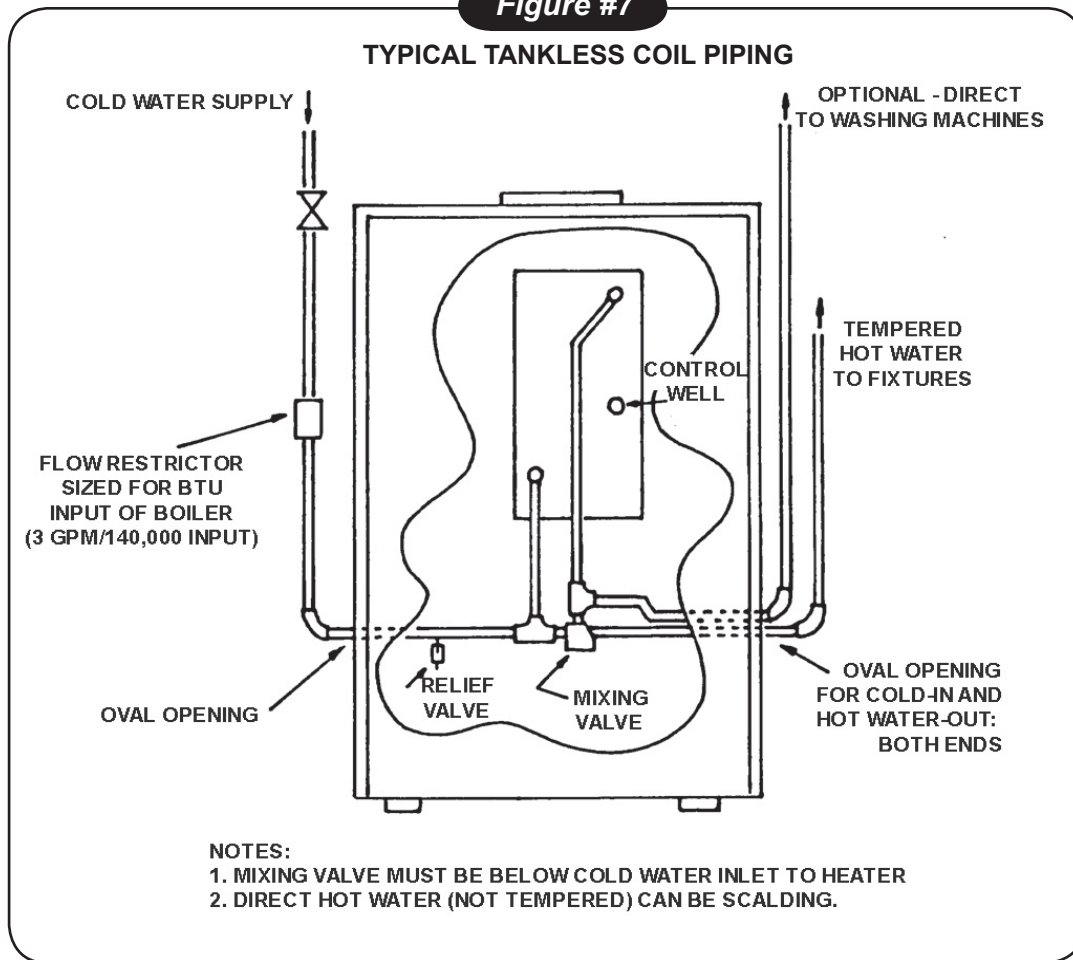

L8151 CONTROL SETTINGS

Use the following setting for the first adjustment:

- High Setting 180°F
- Low Setting 160°F
- Differential 20°F

These settings may be altered based on the heating system response. During very cold weather if the heating system does not provide quite enough heat, the high limit control setting may be raised to a maximum of 200°F. If more domestic hot water is required, the low limit control setting may also be raised to a maximum of 180°F. Whenever adjusting either the high or low limit, the high limit control setting must be set at least 20°F above the low limit. The differential control setting is typically 20°F but may be adjusted to vary the time it takes the burner to respond to a call for domestic hot water.

COLD STANDBY

1. Cold standby is suitable only when thermostatic union is used with piping bypass shown in **Figure #6**.
2. A change in control wiring is also required. To prevent excessive condensation, please contact factory before making this change.
3. Owners of non-tankless boilers often object to the burner starting when space heat is not required. To avoid this, an optional outside thermostat may be used to shut down the system totally when outside temperature is above a specific limit set by the homeowner. See wiring diagrams.

BURNER WIRING

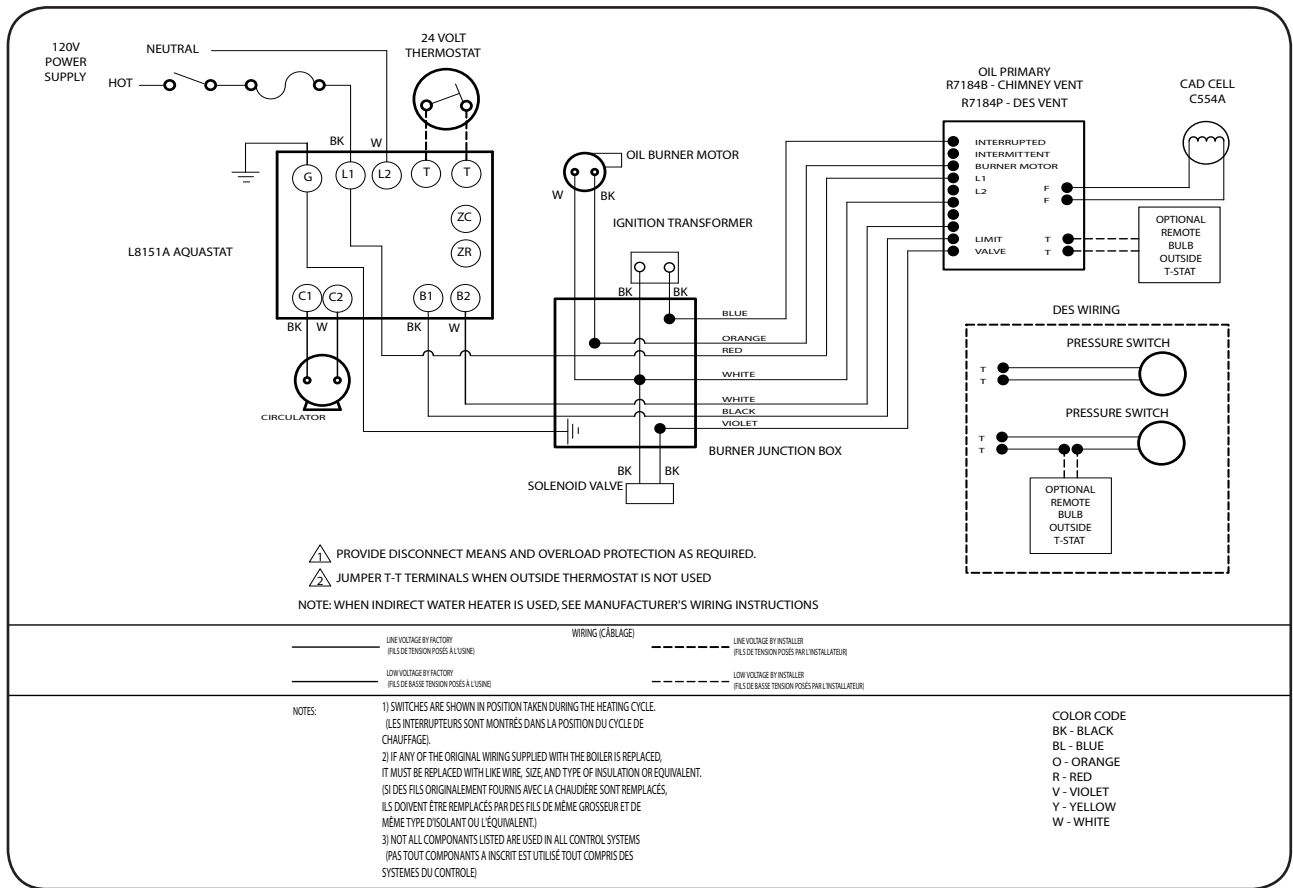

RIELLO BURNER WIRING

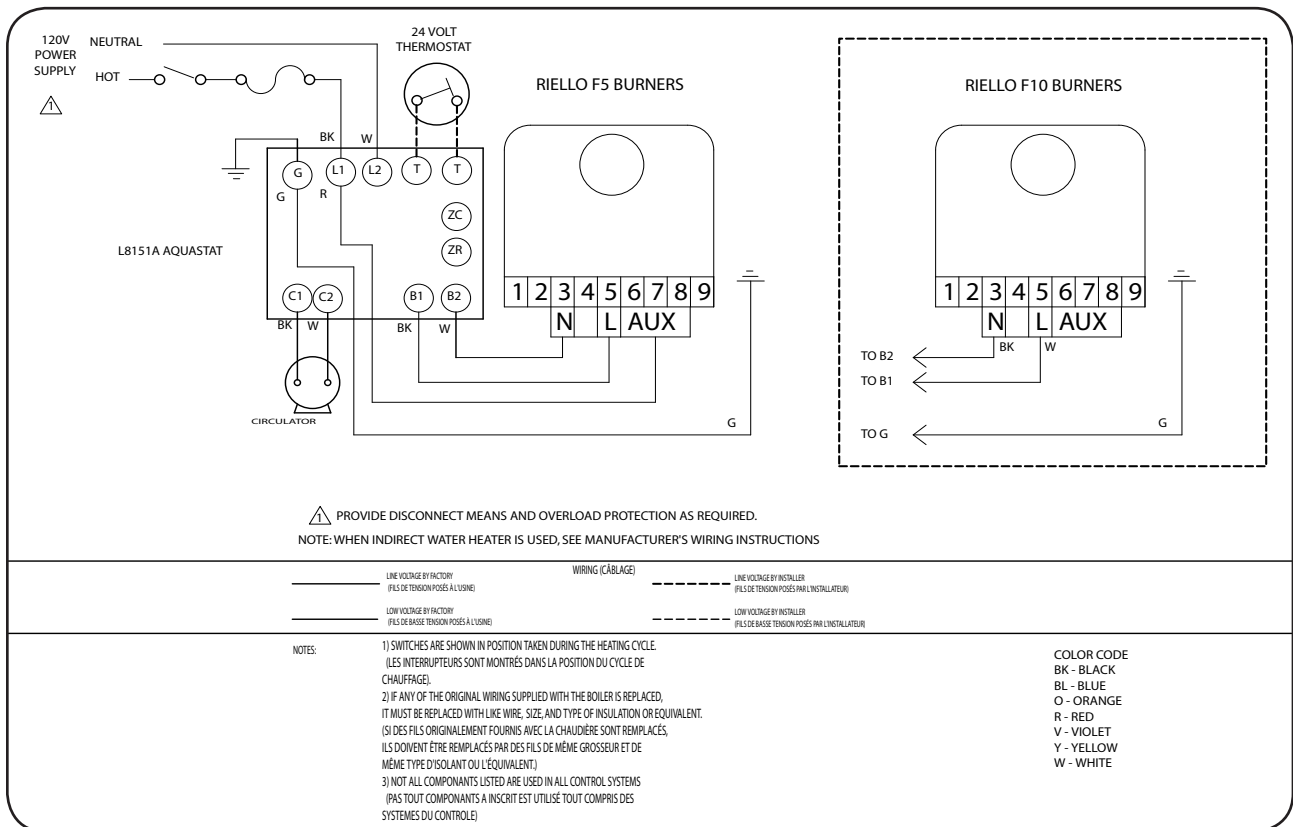

ARGO ARM CONTROL WIRING DIAGRAM

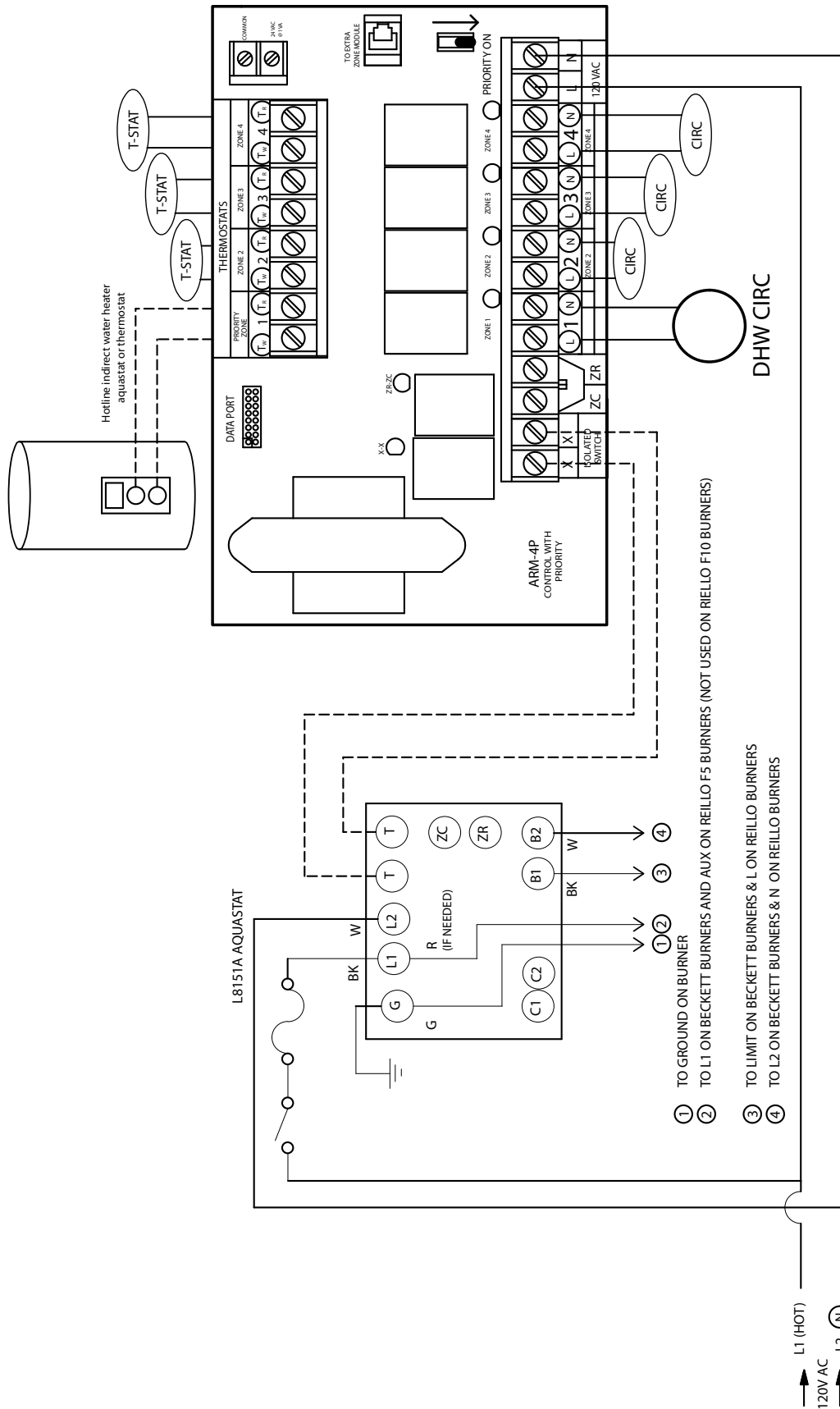

- ① TO GROUND ON BURNER
- ② TO L1 ON BECKETT BURNERS AND AUX ON REILLO F5 BURNERS (NOT USED ON REILLO F10 BURNERS)
- ③ TO LIMIT ON BECKETT BURNERS & L ON REILLO BURNERS
- ④ TO L2 ON BECKETT BURNERS & N ON REILLO BURNERS

L1 (HOT)
120V AC
L2 (N)

ARGO AZP CONTROL WIRING DIAGRAM

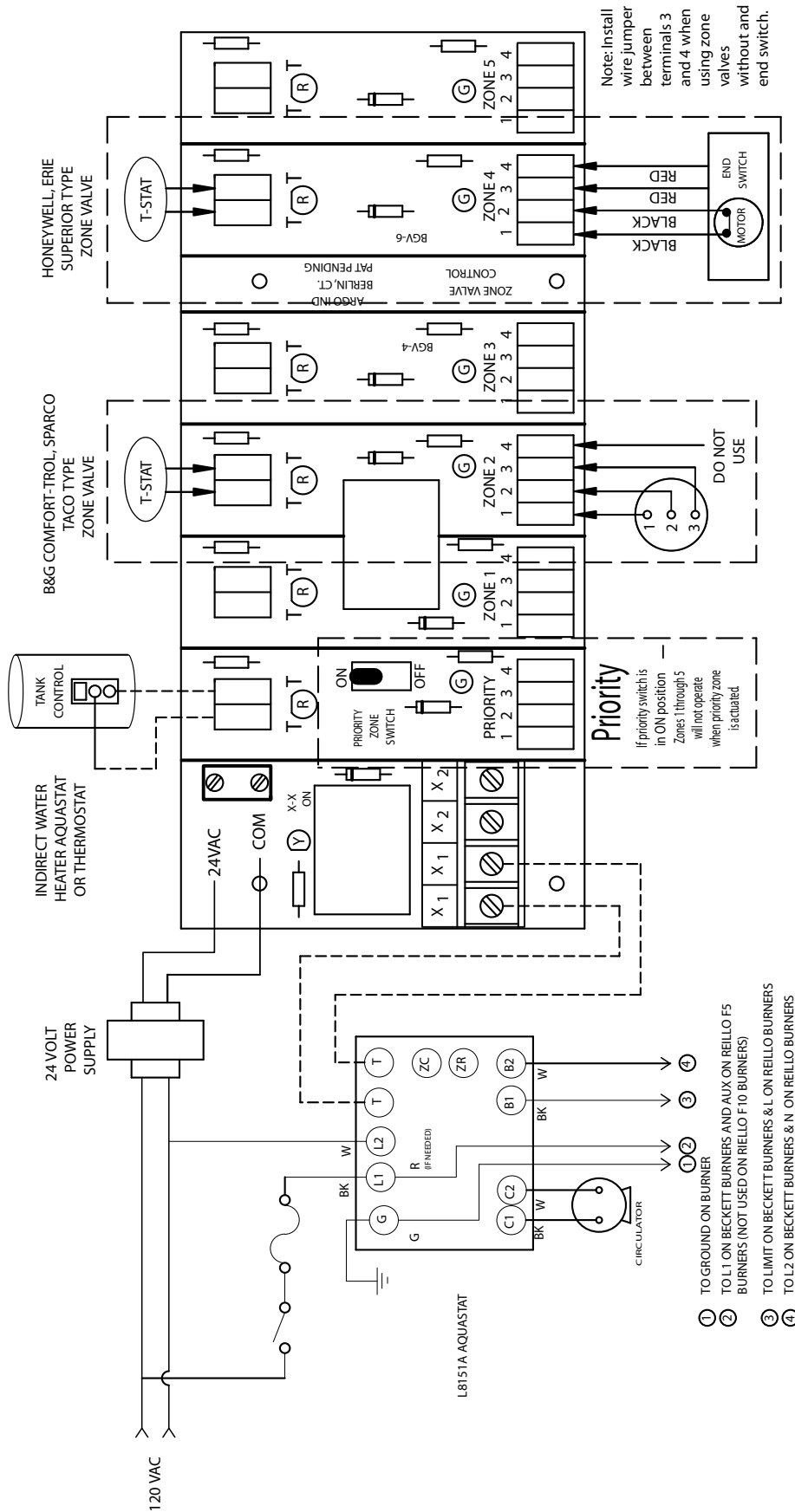

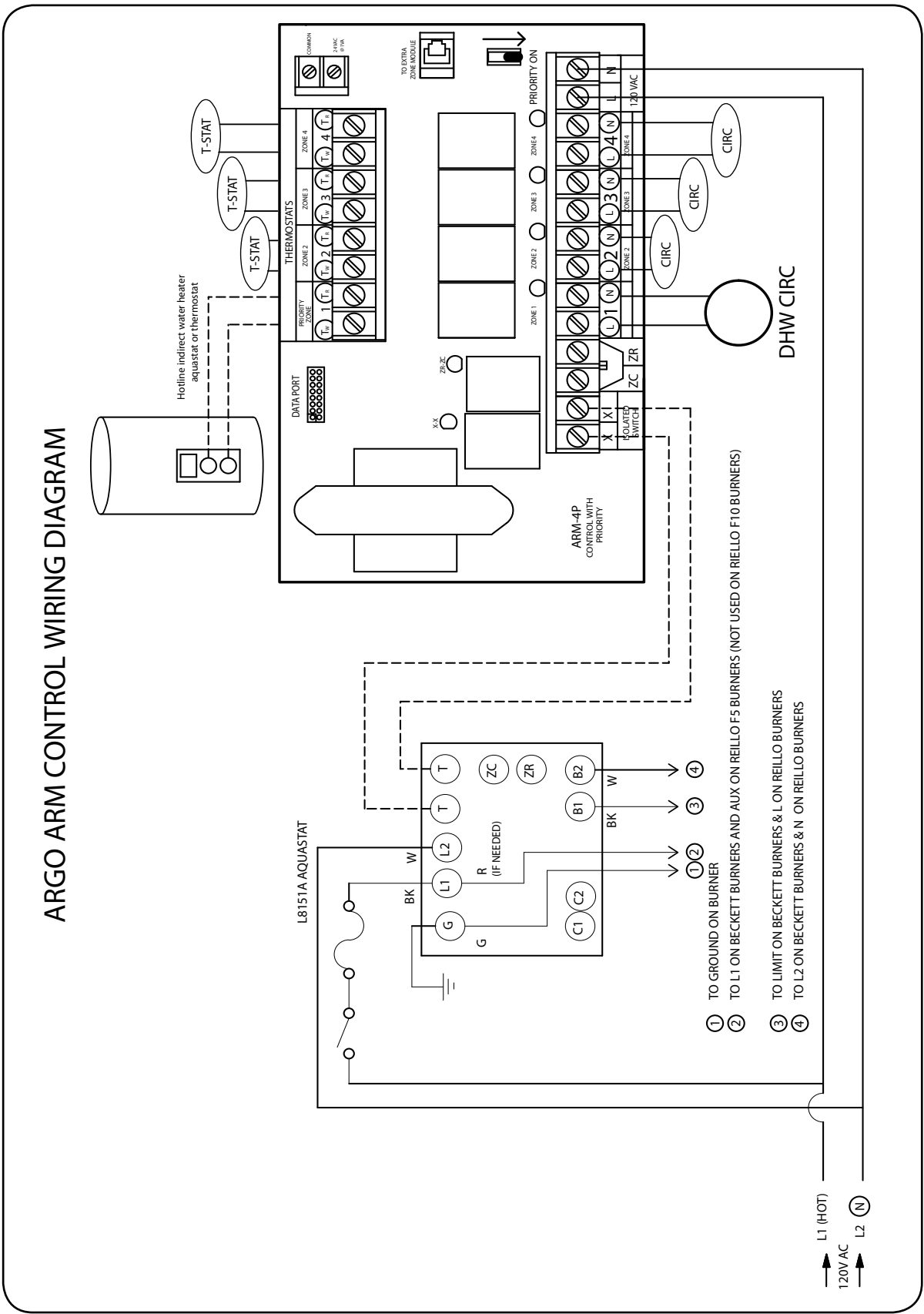

MULTI-ZONE SYSTEM WIRING AND PIPING

ARGO AZP CONTROL WIRING DIAGRAM

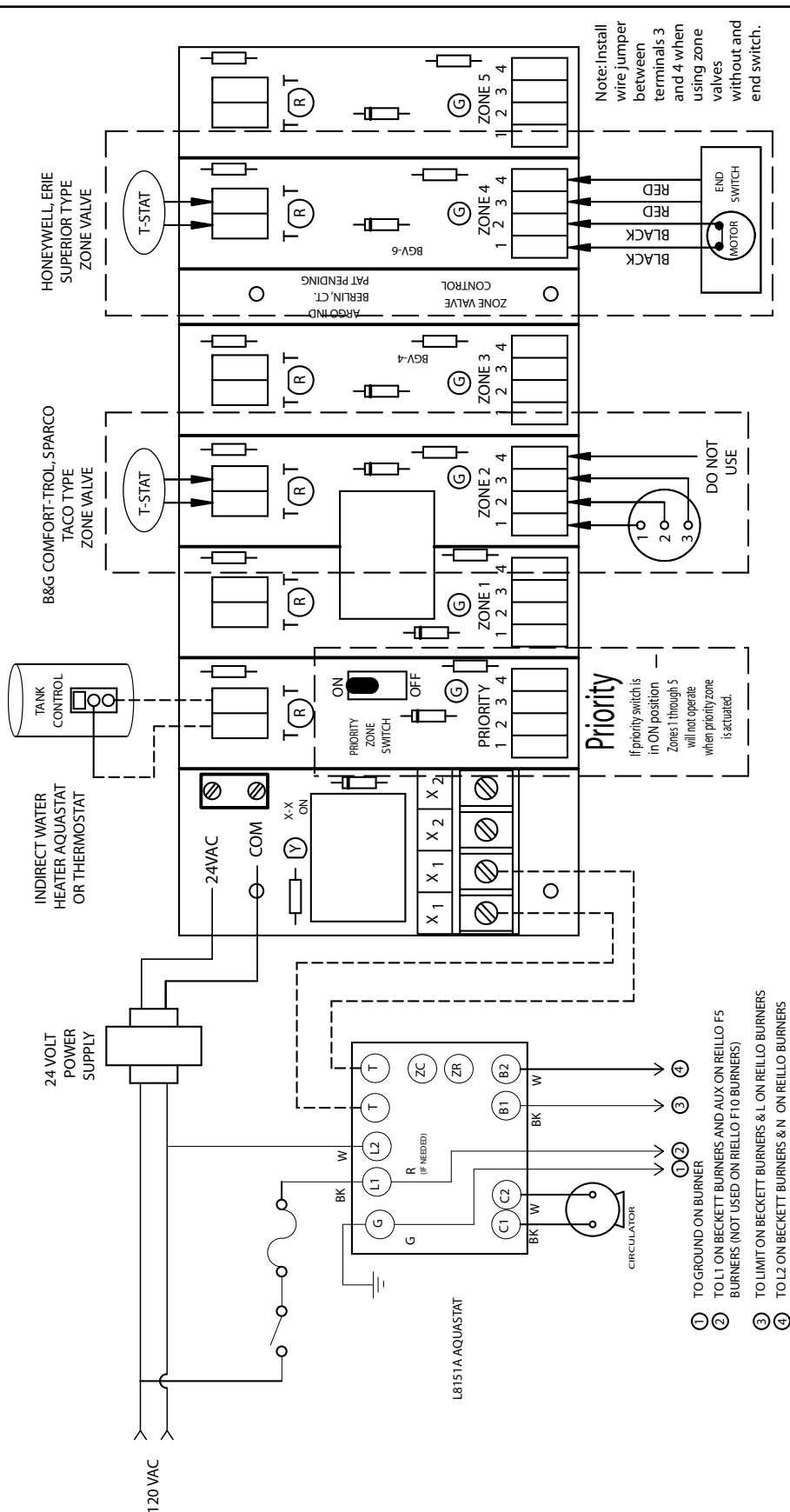

MULTI-ZONE SYSTEM WIRING AND PIPING

PIPING WITH ZONE VALVES

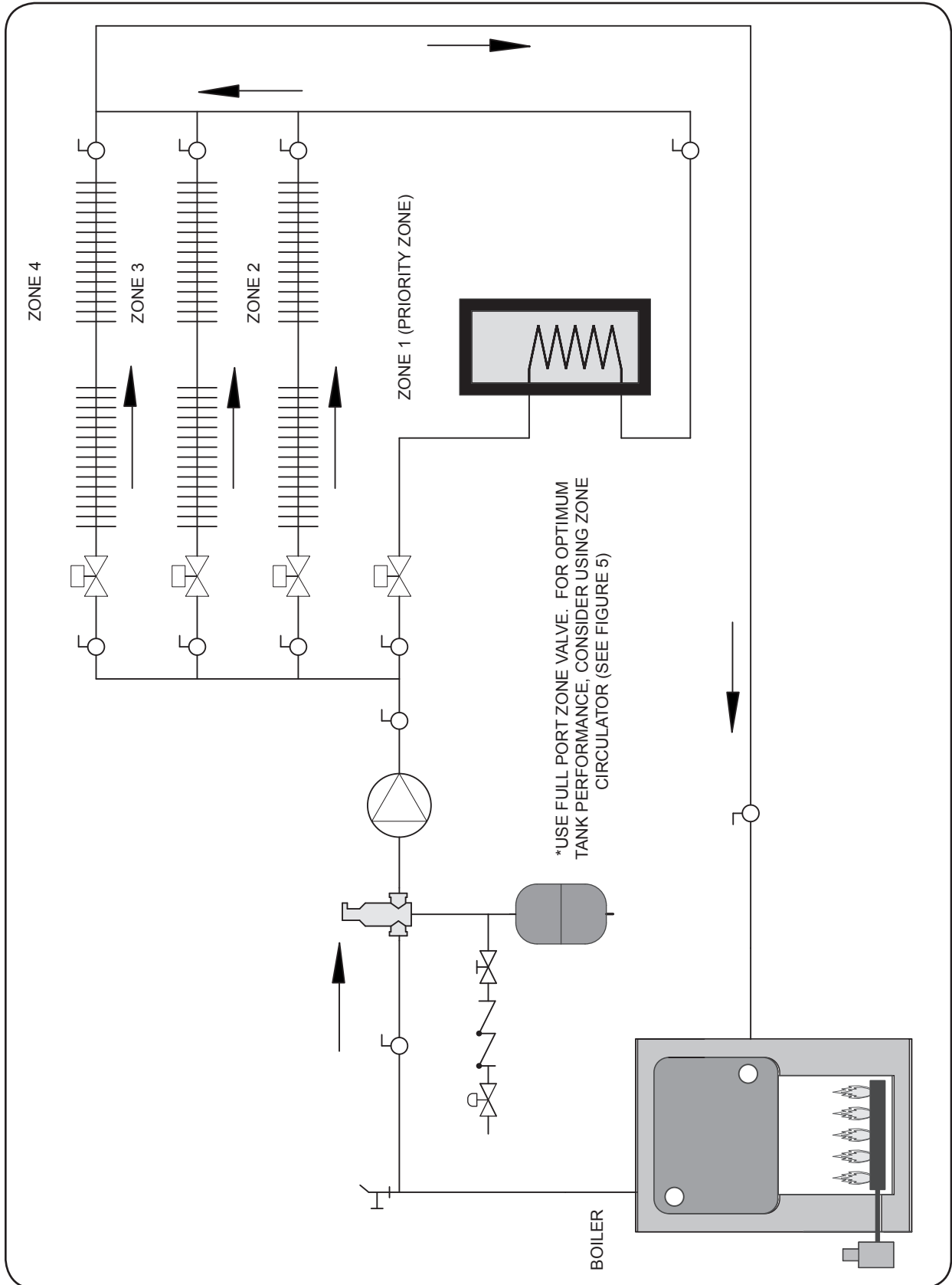

INDOOR OIL BURNER AND CONTROLS (STARTUP AND ADJUSTMENT)

INDOOR CHIMNEY VENTED BOILERS

IMPORTANT: Instruction manual enclosed in burner carton must be followed in regard to startup and adjustment.

1. STANDARD BECKETT AFG OR CF375

OIL BURNER: A Beckett model AFG oil burner is normally supplied with boilers to be fired at 2.00 gph or less. It is equipped with an F3 flame retention head, the size most commonly used. It is possible the head must be changed to match the nozzle firing rate required, and it is recommended the installer carry a complete assortment of Beckett flame retention heads. When head rating overlap, a smaller head with air shutter fairly well open will generally provide better combustion than a larger head with air shutter near closed. See head size selection chart in this manual. For Beckett burners at firing rates above 2.00 gph, a Beckett model CF375 burner is required, and is supplied if specified by purchaser.

2. OPTIONAL RIELLO 40 SERIES OIL BURNER:

Riello 40 series oil burners are optional and only used in chimney vent applications. Model F5 is used for firing rates from 0.90 to 1.50 gph, and Model F10 is used for firing rates from 1.60 to 3.00 gph. Model F5 or F10 is supplied if specified by purchaser.

SUGGESTED NOZZLES, HEADS, AND PRELIMINARY SETTINGS FOR VARIOUS BURNERS AND FIRING RATES ARE SHOWN ON THE FOLLOWING PAGES.

3. On knockdown boilers, the Beckett and Riello burners are not supplied with a nozzle. The correct nozzle is the smallest which will do the job properly. Long continuous runs with minimum starts and stops conserve the most energy. The nozzle which provides the highest CO₂ with the least smoke for a particular application is always recommended. Beckett oil burners are supplied with pump pressure set at 140 psi. Nozzle output will be approximately 18% greater than that at 100 psi. Pump pressure on Riello burners should be adjusted according to settings in "Suggested Nozzles and Settings for Riello Burners" in the **Burner Setups** section of this manual.

⚠ CAUTION ⚠

Too low a firing rate can cause excessive condensation within the boiler and chimney resulting in severe rust and corrosion. A piping bypass is recommended to minimize this problem.

4. If Beckett AFG burner is to be fired at less than 1.00 gph, it is possible that a low firing rate baffle will be required. Refer to the burner setup charts in this manual for full burner setup details.
5. Using three acorn nuts, studs, and washers from hardware package, fasten burner to mounting plate.
6. Mount L8151 control on boiler jacket above and to the right of burner using sheet metal screws in holes located in jacket. Wiring harness is provided. When well is used at the rear of a larger boiler, it might be necessary to relocate the control with longer wiring not provided.
7. If the boiler is equipped with a tankless coil, insert well for the L8151 remote bulb in coil plate. Run capillary tube through sight glass opening in jacket.
8. If a tankless coil is not used, install ¾" well and bulb with a bushing either in the 1½" supply opening opposite the one used to feed radiation, or in a reducing tee in the 1½" supply opening that actually feeds radiation.
9. The wiring diagram is found in the **Burner Wiring** section of this manual. To avoid excessive condensation, do not use a two-stage thermostat or other fuel saving devices or techniques without first contacting the factory.
10. Before making control adjustments, verify that all fuel, water, and electrical connections have been made in accordance with the regulations of the National Fire Prevention Association, the National Electrical Code and/or local regulations. (See "L8151 Control Settings" in this manual for more information.)

INDOOR OIL BURNER AND CONTROLS (STARTUP AND ADJUSTMENT)

11. **START-UP AND ADJUSTMENT:** Start and adjust burner according to manufacturer's instructions contained in burner carton or included with packaged boiler, and pay special attention to the following:

- a. As the name suggests, this boiler is designed to produce the ultimate in usable heat from a gallon of fuel oil.



WARNING

DONOTADJUSTAIR-FUELMIXTUREBYEYE. Adjusting air-fuel mixture by eye wastes fuel and creates soot. Any time air adjustment or oil rate is changed, combustion must be checked with instruments.

- b. With chamber fully warmed up, find the highest CO₂ level at which zero smoke can be maintained. Then add extra air until CO₂ falls off 1%. Final setting should be at least 11% CO₂. If unable to obtain that reading, check for internal oil leaks, incorrect flame retention head or a faulty or incorrect nozzle. (Refer to the burner setup charts in this manual for full burner setup details.) Draft will vary as air is adjusted. It should be left at as near zero as possible at the breech.

Complete installation must be made in accordance with the requirements of local authorities and the National Fire Protection Association.

With all high efficiency boilers, care must be taken to minimize condensation. Therefore, cold standby is not recommended and may be used only with a piping, bypass as shown on Figure 6. This requires a change in control wiring. Please contact factory prior to making that change.

When cold standby is not utilized, the homeowner might object to the burner starting when space heat is not required. To avoid this, an optional outside thermostat may be used to shut down the system when outside temperature is above a specific limit set by the homeowner. When outside thermostat is not used, Jumper T-T Terminals on relay.

L8181 CONTROL SETTINGS

Use the following setting for the first adjustment:

High Limit Set Point 180°F
Low Limit Set Point 160°F
Differential..... 20°F

These settings may be altered based on the heating system response. During very cold weather if the heating system does not provide quite enough heat, the high limit control setting may be raised to a maximum of 200°F. If more domestic hot water is required, the low limit control setting may also be raised to a maximum of 180°F. Whenever adjusting either the high or low limit the high limit control setting must be set at least 20°F above the low limit. The differential control setting is typically 20°F above the low limit. The differential control setting is typically 20°F but may be adjusted to vary the time it takes the burner to respond to a call for domestic hot water.

INDOOR DIRECT EXHAUST BOILERS

Instruction manual enclosed in burner carton must be followed in regard to start-up and adjustment.

1. A Beckett model AFG post-purge oil burner is normally supplied with boilers to be fired at 2.00 gph or less. It is equipped with an F3 flame retention head, the size most commonly used. It is possible the head must be changed to match the nozzle firing rate required, and it is recommended the installer carry a complete assortment of Beckett flame retention heads. When head ratings overlap, a smaller head with air shutter fairly well open will generally provide better combustion than a larger head with air shutter near closed.

2. At firing rates above 2.00 gph, a special Beckett model CF375 burner must be used and is supplied if specified by purchaser.

3. Post-purge oil burners are supplied with pump pressure set at 140 psi. Nozzle output will be approximately 18% greater than that at 100 psi.

4. **The burner is not supplied with a nozzle.** The correct nozzle is the smallest which will do the

INDOOR DIRECT EXHAUST BOILERS

job properly. Long continuous runs with minimum starts and stops conserve the most energy. The nozzle which provides the highest CO₂ with the least smoke for a particular application is always recommended.

WARNING

Too low a firing rate can cause excessive condensation within the boiler and flue resulting in severe rust and corrosion. A piping by-pass is recommended to minimize this problem.

5. Using acorn nuts, studs, and washers from hardware package, fasten burner to mounting plate. Do not disturb chamber when inserting firing head.

6. Mount L8151 control on boiler jacket above and to the right of burner using sheet metal screws in holes located in jacket. Wiring harness is provided. When well is used at the rear of a larger boiler, it might be necessary to relocate the control with longer wiring not provided.

7. If boiler has a tankless coil, insert well for the L8151 remote bulb in coil plate. Run capillary tube through sight glass opening in jacket.

8. If a tankless coil is not used, install 3/4" well and bulb with a bushing either in the 1 1/2" supply opening opposite the one used to feed radiation, or in a reducing tee in the 1 1/2" supply opening that feeds radiation.

9. Mount overfire pressure switch at upper right of burner on screws already in jacket. Burner will shut down if overfire pressure reaches .35" w.c. due to a plugged flue or high wind. See "*Vent Safety Switch Installation*" in this installation and operation manual for more information.

10. Wiring diagram is found in the **Burner Wiring** section of this manual. To avoid excessive condensation, do not use a two-stage thermostat or other fuel saving devices or techniques without first contacting the factory.

11. Install Gar-Ber filter as provided rather than a standard filter between burner and oil storage tank.

12. Before making control adjustments, verify that all fuel, water, and electrical connections have been made in accordance with the regulations of the National Fire Prevention Association, the National Electrical Code, and/or local regulations.

13. **STARTUP AND ADJUSTMENT:** Start and adjust burner according to manufacturer's instructions contained in burner carton or included with boiler and pay special attention to the following:

a. As the name suggests, this boiler is designed to produce the ultimate in usable heat from a gallon of fuel oil.

WARNING

DONOT ADJUST AIR-FUEL MIXTURE BY EYE. Adjusting air-fuel mixture by eye wastes fuel and creates soot. Any time air adjustment or oil rate is changed, combustion must be checked with instruments.

b. With chamber fully warmed up, find the highest CO₂ level at which zero Smoke can be maintained. Then add extra air until CO₂ falls off 1%. Final setting should be at least 11% CO₂. If unable to obtain that reading, check for internal oil leaks, incorrect flame retention head, or faulty or incorrect nozzle.

14. **POST PURGE TIMING:** With through-the-wall venting there is no overfire draft present after the burner shuts down. Therefore a post purge must be used to prevent the hot chamber from overheating the nozzle.

The post purge timer is part of the Honeywell intermittent primary control, which is located on the Beckett oil burner. The post purge time has been preset to 4 minutes but may be adjusted to 0, 2, 4, or 6 minutes by adjusting the switches on the side of the intermittent primary control. With a stack thermometer in place, the boiler fully warmed up (200°F or more), and the boiler running, turn the high limit control on the aquastat all the way down. The burner motor should then be running with the flame off (i.e., in post purge). Measure the time it takes from the flame off until the stack temperature

INDOOR DIRECT EXHAUST BOILERS

falls to the same temperature as the boiler water. Adjust the post purge timer to nearest time interval, always rounding up if possible. For example, if the time measured is 3 minutes and 20 seconds, then set the post purge timer at 4 minutes.

Whenever the nozzle is removed for service, check for varnish forming on the outside of the nozzle. If carbon and varnish do not wipe off easily, increase the post purge time.

15. LIMITED RECYCLE AND LIMITED RESET: The Honeywell R7184P1031 interrupted-duty primary control utilizes two safety features to protect the boiler from being saturated with oil. Limited recycle will allow the burner 3 attempts to ignite, if ignition is unproven the control locks out. The control's reset button can then be pressed. The limited reset feature will allow the burner to be reset 3 times before it locks out. To unlock the control requires the reset button to be held for 30 seconds.

16. ELECTRICAL WIRING: Wiring should conform with the latest edition of the National Electrical Code ANSI/NFPA No. 70 in the United States and the CSA C22.1 Canadian Electrical Code in Canada and/or the local authority having jurisdiction. A separate electrical circuit should be run from the entry box with a fused disconnect switch in this circuit. Refer to wiring diagrams for suggested circuitry and field wiring. Wiring for zone valve installations are furnished with zone valve packages.

Complete installation must be made in accordance with the requirements of the local authorities and the National Fire Protection Association.

With all high efficiency boilers, care must be taken to minimize condensation. Therefore, cold standby is not recommended and may be used only with a piping bypass as shown in Figure 6. This requires a change in control wiring. Please contact factory prior to making that change. When cold standby is not utilized, the homeowner might possibly object to the burner starting when space heat is not required. To avoid this, an optional outside thermostat may be used to shut down the system totally when outside temperature is above a specific limit set by the homeowner.

L8151 CONTROL SETTINGS

High Setting	180°F
Low Setting	160°F
Differential	20°F

These settings may be altered based on the heating system response. During very cold weather if the heating system does not provide quite enough heat, the high limit control setting may be raised to a maximum of 200°F. If more domestic hot water is required, the low limit control setting may also be raised to a maximum of 180°F. Whenever adjusting either the high or low limit the high limit control differential control setting is typically 20°F above the low limit. The differential control setting is typically 20°F but may be adjusted to vary the time it takes the burner to respond to a call for domestic hot water.

WEATHERPROOF (OUTDOOR) BOILER INSTALLATION

WATERPROOF (OUTDOOR) BOILER LOCATING THE BOILER

1. Place boiler at a location as centralized as possible with the piping system and as free from unusual wind currents as possible.
2. A level concrete or noncombustible base is recommended with the top high enough so that ground water and melted snow will not rise as high as the bottom of the boiler. It is also recommended that crushed stone or gravel surround the base to keep shrubbery, weeds and grass at least 18" from the boiler.
3. If necessary, level boiler with shims placed beneath feet.
4. Accessibility clearances must take precedence over fire protection clearances. Allow at least 24" for servicing at the front and burner sides of the boiler. Allow at least 18" at a side where passage is required to another side for servicing. A 6" clearance from combustible material on all sides and the top is recommended.
5. Advise owner to maintain air passages free from obstructions. Ventilating and combustion air must enter boiler casing without restrictions.

WATERPROOF (OUTDOOR) BOILER ASSEMBLY AND PIPING

1. Install 1½" nipples (not supplied) or smaller nipples with bushings in the two tappings in end of boiler opposite burner. These will provide feed to the radiation and return to the boiler. Supply pipe should be level or rise slightly toward air vent inside building. See **Figure #8** for alternative air elimination method.
2. Circulator, make-up water, expansion tank, etc., should be installed at a convenient location inside the building.

a. Domestic Water Heating: See Figure 14 for piping of remote (indoor) tankless coil or indirect water heater. An indirect Water Heater is recommended.

b. Without Domestic Water Heating: See **Figure #9**.

3. Place control well in top ¾" tapping near burner end of boiler.

4. Install a ¾" street ell in remaining top tapping. Mount relief valve on street ell using a ¾" x 7" nipple. Mount ¾" overflow pipe (not supplied) so that it extends downward beside boiler casting and will be covered by boiler jacket when jacket is in place. Do not extend overflow pipe so near the ground that it might become clogged with snow or ice.

5. At burner end of boiler mount thermostat with 1½" x ½" bushing in upper right 1½" tapping.

6. Install boiler drain with bushing in lower left 1½" tapping.

Figure #8

ALTERNATIVE AIR ELIMINATION METHOD

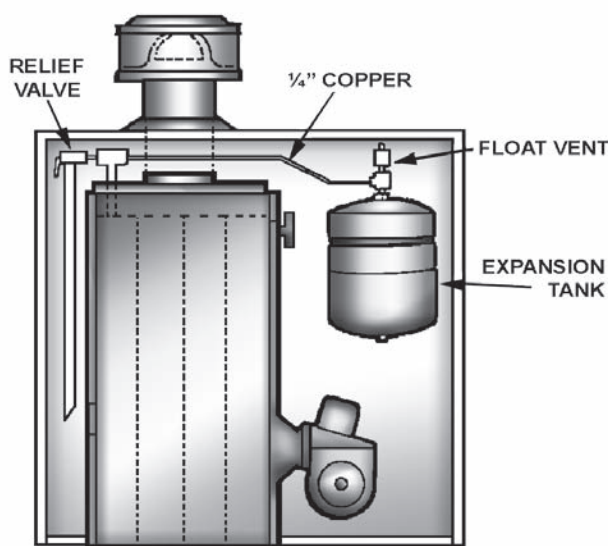

WATERPROOF (OUTDOOR) BOILER ASSEMBLY AND PIPING

Figure #9

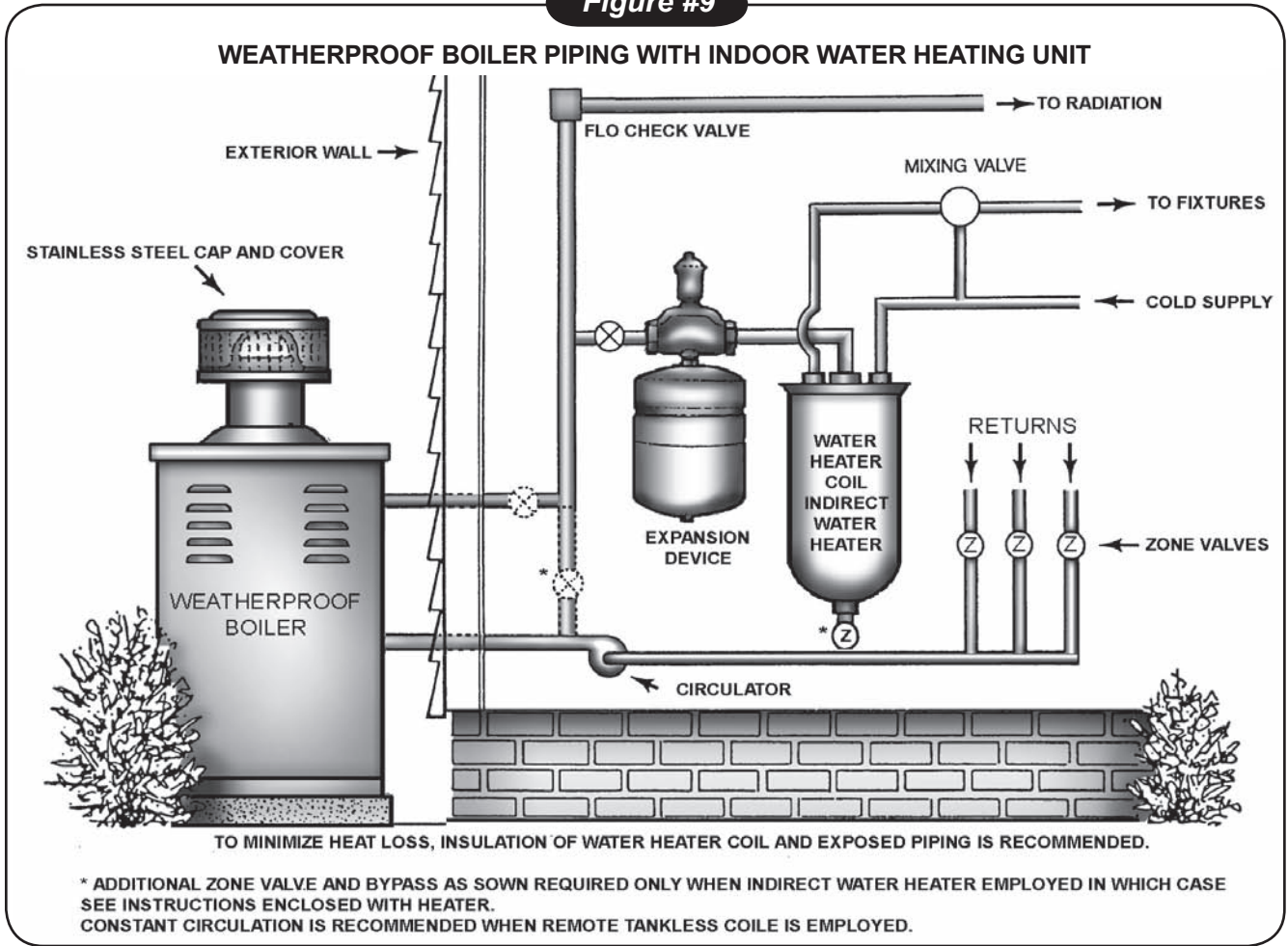
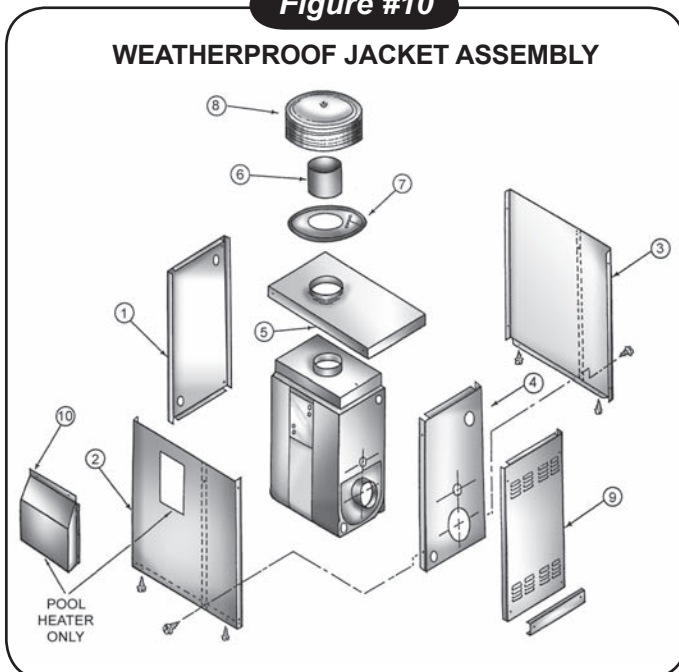

Figure #10



7. Referring to **Figure #10**, place panel 1 over supply and return pipe nipples.

8. Attach panels 2 and 3 to panel 1 using sheet metal screws supplied.

9. Attach panel 4 to panels 2 and 3.

10. Fasten L8151 control to upper right-hand side of panel 4 with bulb in control well already in place.

11. Install additional controls according to manufacturer's instructions included and to **Figures #11** on next page.

WATERPROOF (OUTDOOR) BOILER ASSEMBLY AND PIPING

Figure #10

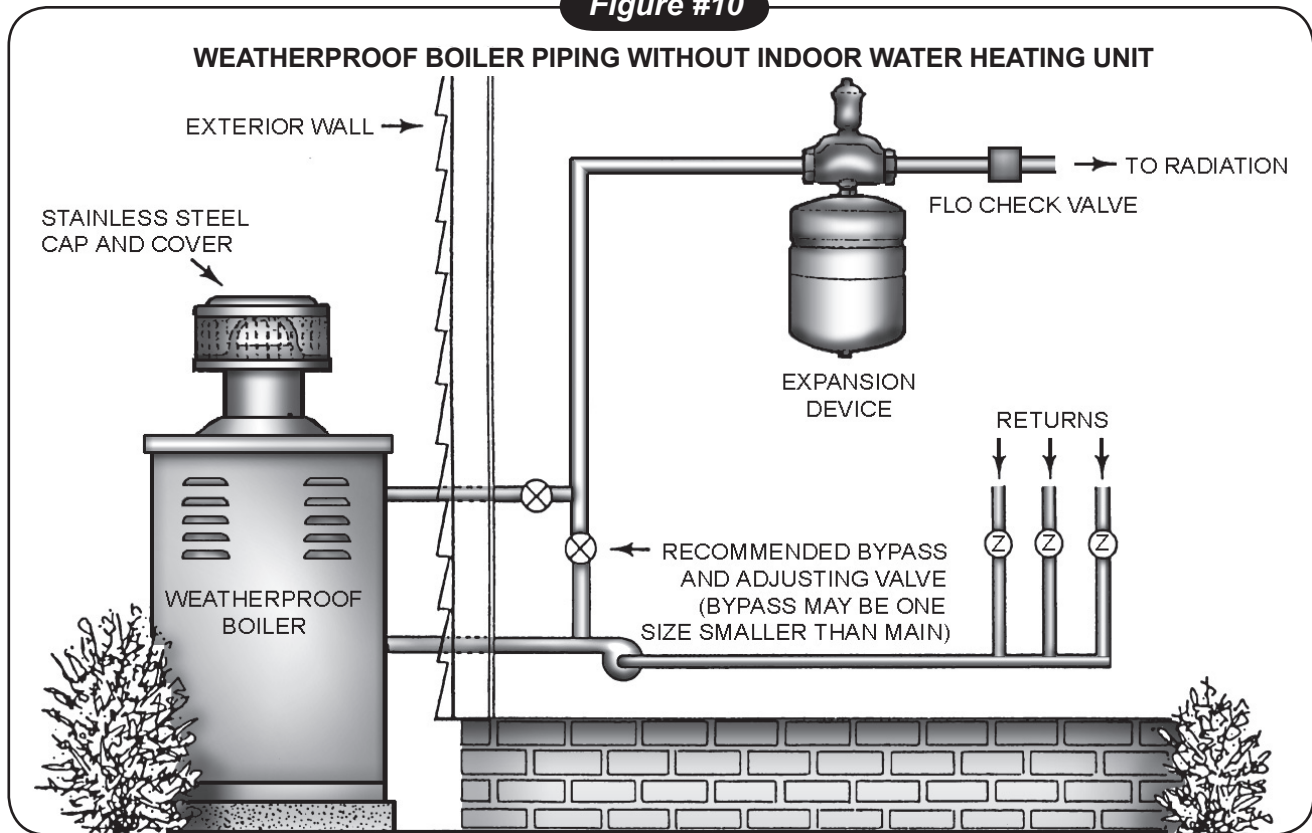

12. Install burner according to manufacturer's instructions with particular attention given to the following **IMPORTANT** information:

BECKETT RETENTION HEAD SELECTION CHART

Use Model AFG Burner up to 2.00 gph only

Head Size	F0	F3	F6	F12	F22
Max. Firing Rate	.75	1.25	1.65	1.75	2.00

TYPICAL NOZZLE TYPES AND SIZES FOR BECKETT BURNERS

Boiler Model	Nozzle
PFO-3T2W, PFO-4W	80° Hollow or Solid
PFO-6T2W, PFO-7AW, PFO-7SW	70° or 80° Hollow or Solid
All Larger Models	60° or 70° Hollow or Solid

a. Oil Installations: See charts (below) for firing rate head sizing and nozzle sizing instructions. The F3 head supplied might not be the correct size to match the firing rate required for this particular installation.

b. Fasten burner to burner mounting plate using three studs, washers, and acorn nuts from hardware package. Be very careful to avoid

disturbing combustion chamber when inserting air tube. Retention head must be set flush with inside wall of combustion chamber.

13. Connect piping to distribution system referring to **Figure #9** for systems with domestic water heating or to Figure 15 for systems without.

14. Verify that fuel, water, and electrical connections have been made in conformance with all applicable codes.

15. Fill and test boiler and systems. Weatherproof space heating boilers require antifreeze. See "Antifreeze" on this page for more information.

16. Cover all outdoor piping with weather-resistant insulation.

17. Start burner according to manufacturer's instructions and make combustion tests. It is suggested that the short length of smoke pipe be installed temporarily for ease in making tests. (See *startup and adjustment instructions for oil and gas installations in this manual for more information.*)

WATERPROOF (OUTDOOR) BOILER ASSEMBLY AND PIPING

Figure #11

BECKETT BURNER WIRING DIAGRAM FOR WEATHERPROOF OIL-FIRED BOILER (SPACE HEATING)

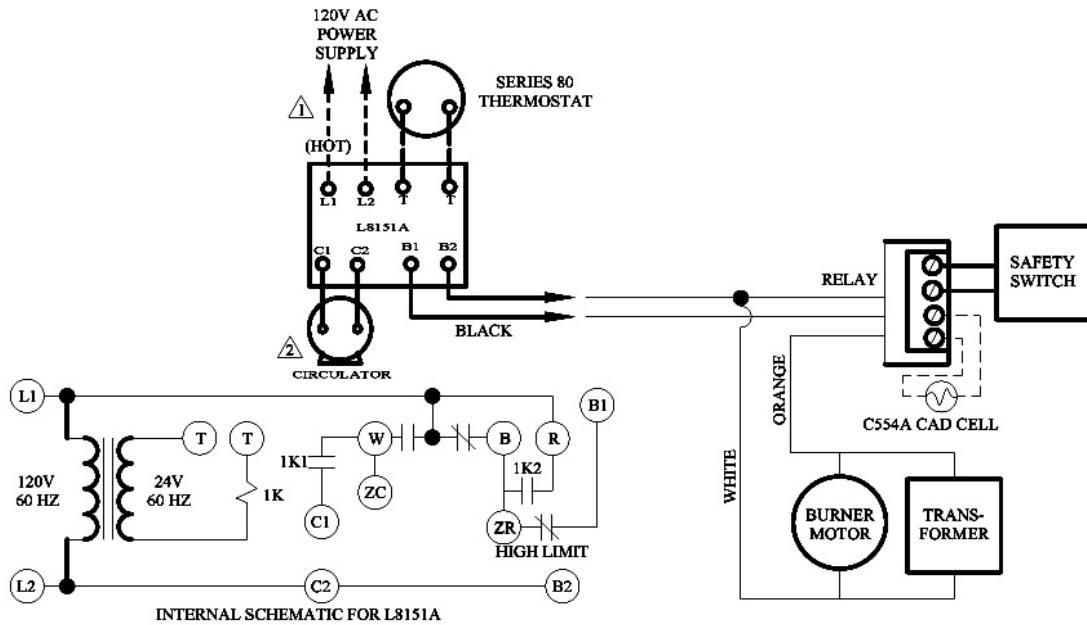

- ⚠ PROVIDE DISCONNECT MEANS AND OVERLOAD PROTECTION AS REQUIRED.
 - ⚠ JUMPER T-T TERMINALS WHEN OUTSIDE THERMOSTAT IS NOT USED
- NOTE: WHEN INDIRECT WATER HEATER IS USED, SEE MANUFACTURER'S WIRING INSTRUCTIONS

18. Referring again to **Figure #10**, fasten front jacket panel (#9) in position with sheet metal screws and install jacket top (#5).

19. Install exhaust assembly with parts 6, 7, and 8. The exhaust cap is made to spring inside the short length of smoke pipe. A tourniquet made of wire or a large hose clamp may be used to reduce the diameter so that it will fit inside the pipe. Two or three hose clamps in series may be used when a large one is not available.

ANTIFREEZE

1. Antifreeze added to boilers must be non-toxic and must be of a type specifically intended for use in closed hydronic heating systems. Under no circumstances should automotive antifreeze be used.

2. Use of antifreeze in any boiler may reduce capacity by 10% or more and increase fuel consumption. Tankless coil performance will fall as concentration of antifreeze is increased.

3. Because antifreeze forms slush rather than hard ice, it is safe to protect only to 10 degrees above coldest temperature anticipated provided slush formed can move towards expansion tank.

WATER VOLUMES OF PF SERIES BOILERS

MODEL	VOL. (GAL.)	MODEL	VOL. (GAL.)
PF3	7	PF3T	10
PF4	9	PF4T	12
PF5	11	PF5T	14
PF7	15	PF6T	16
PF9	19	PF8T	20
		PF7TT	21

PIPING VOLUMES

Divide total length of piping in feet by factor (below) to determine water volume in gallons.

PIPE MATERIAL	PIPE SIZE					
	1/2"	3/4"	1"	1 1/4"	1 1/2"	2"
COPPER	82.5	40.0	23.3	15.3	10.8	6.2
STEEL	63.5	36.0	22.2	12.8	9.5	5.8

WEATHERPROOF OIL BURNER AND CONTROLS (STARTUP AND ADJUSTMENT)

ALTERNATE AIR ELIMINATION METHOD

As boiler temperature increases, air will move from top of boiler toward float vent even if lower. As boiler temperature decreases, water will move from expansion tank toward boiler. (See **Figure #8**)

This boiler was designed to produce the ultimate in usable heat from a gallon of fuel oil.



WARNING

DONOTADJUSTAIR-FUELMIXTUREBYEYE. Adjusting air-fuel mixture by eye wastes fuel and creates soot. Any time air adjustment or oil rate is changed, combustion must be checked with instruments.

With chamber fully warmed up, find highest CO₂ level at which zero smoke can be maintained. Then add extra air until CO₂ falls off about 1%. Final setting should be at least 11% CO₂. If unable to obtain that reading, check for internal oil leaks, incorrect flame retention head or faulty or incorrect nozzle. Draft will vary as air is adjusted. It should be left at as near zero as possible at breeching.

The correct nozzle is the smallest which will do the job properly. Long continuous runs with minimum starts and stops conserve the most energy. The nozzle which provides the highest CO₂ with the least smoke for a particular application is always recommended.



WARNING

A firing rate that is too low can result in a condensation problem within the chimney and boiler, causing severe rust and corrosion. When domestic water is being heated, bypass piping is recommended only when an indirect water heater is used as shown on Figure 14. If no domestic water heating is involved, by-pass piping is always recommended as shown on Figure #6.

BECKETT AFG OR CF375 OIL BURNER

A Beckett model AFG oil burner is used to fire boilers at 2.00 gph or less. At firing rates above 2.00 gph, a Beckett model CF375 is required. A model AFG burner shipped with your PF Series boiler is equipped with an F3 flame retention head, the size most commonly used. It is possible the head must be changed to match the nozzle firing rate required, and it is recommended the installer carry a complete assortment of Beckett flame retention heads. When head ratings overlap, a smaller head with air shutter fairly well open will generally provide better combustion than a larger head with air shutter near closed. See head size selection chart on page 21. For firing rates under 1.00 gph. see page 18 for information on using low firing rate baffles.

It should be recognized that the description of spray patterns might vary between nozzle manufacturers. In any case the nozzle recommended is that which provides the highest CO₂ with the least smoke for a particular application.

SUGGESTED NOZZLES, HEADS, AND PRELIMINARY AIR SETTINGS FOR VARIOUS FIRING RATES AND BURNERS ARE SHOWN ON PAGES 6 AND 7.

L8151 CONTROL SETTINGS

Use the following setting for the first adjustment:

High Setting	180°F
Low Setting	160°F
Differential.....	20°F

These settings may be altered based on the heating system response. During very cold weather if the heating system, does not provide quite enough heat, the high limit control setting may be raised to a maximum of 200°F. If more domestic hot water is required, the low limit control setting may also be raised to a maximum of 180°F. Whenever adjusting either the high or low limit the high limit control setting must be set at least 20°F above the low limit. The differential control setting is typically 20°F but may be adjusted to vary the time it takes the burner to respond to a call for domestic hot water.

NORMAL SEQUENCE OF OPERATION

On a call for heat, the thermostat will actuate, completing the circuit to the aquastat. In turn the circulator and ignition systems are activated and ignition will begin. In the event the boiler water temperature exceeds the high limit setting on the boiler mounted aquastat, power will be interrupted between the aquastat and the ignition system. The power will remain off until the boiler water temperature drops below the high limit setting. The circulator will continue to operate under this condition until the thermostat is satisfied.

SIDEWALL VENTED (CATEGORY III) BOILERS

Should a blocked flue condition occur, the pressure switch will sense a drop in pressure, opening the circuit to the ignition system. For oil burners the switch will reset after the burner goes out post-purge and attempt to relight. After three attempts to light, the burner will go into permanent lockout.

Do not attempt to place the boiler back into operation. Contact a qualified service agency.

OPERATING INSTRUCTIONS - OIL BURNERS

The venting system should be inspected at the start of each heating season. Check the vent pipe from the boiler to the chimney for signs of deterioration by rust or sagging joints. Repair if necessary.

Remove the vent pipe at the base of the chimney or flue and, using a mirror, check for obstruction.

The lever of the pressure relief valve on the boiler should be operated periodically to make sure that it is functioning properly. The pressure relief valve should open before the water pressure exceeds the 30 lb. reading on the gauge. If this pressure is exceeded and the pressure relief valve leaks water when the boiler is operating at normal pressures, it should be immediately replaced. Corrosion can build up rapidly at the valve seat and prevent its functioning as a safety device.

WARNING
WATER WILL BE BOILING HOT.

START-UP AND ADJUSTMENT OF BURNER

(See oil burner instructions for nozzle and electrode setting.)

1. Check oil burner nozzle to make certain it is tight in adapter. Burner mounting bolts should be tight.
2. Check electrode setting, as they may have been jarred out of position during transportation.
3. Lubricate burner motor and circulator motor if required. Some circulators are water lubricated and do not require oiling.
4. Set room thermostat to call for heat, or jump thermostat contacts on the boiler control.
5. Open all oil line valves.
6. Turn service switch on. Burner should start.
7. On one pipe fuel systems only, vent pump as soon as burner starts. Allow oil to run until all traces of air in the suction line disappear.
8. Turn "OFF" burner and install pressure gauge port on pump.
9. Start burner again and check oil pressure for 140 pounds. Adjust if necessary.

CAUTION
DO NOT SET FIRE VISUALLY.

Instruments are the only reliable method to determine proper air adjustments. An improperly adjusted burner causes soot and high fuel bills because of incomplete combustion of the fuel oil. This in turn may require excessive boiler maintenance, service costs, and in some instances, house cleaning or re-decorating. A competent service mechanic should be consulted to make the proper adjustments with a smoke tester, CO₂ indicator and draft gauge. Bacharach or Dwyer test kits include these instruments.

NORMAL SEQUENCE OF OPERATION

PROPER OPERATION OF THE BOILER BURNER UNIT

A ¼" diameter slot is provided in the inspection cover plate to take draft readings in the combustion chamber. A ¼" diameter hole will be required in the flue pipe between the boiler and barometric damper (if used) to take draft, CO₂, smoke and temperature readings. Adjust air shutter on oil burner to obtain a "trace" of smoke. Measure CO₂ at this point. Increase air adjustment to lower CO₂ approximately 1%. Check to insure minimum -.02 w.c. "overfire" draft, and zero smoke. If -.02 w.c. "overfire" draft can not be maintained, changes and/or modifications may be required in the venting or the chimney.

CHECK SAFETY CONTROL CIRCUIT after burner adjustments have been made for satisfactory performance.

1. High Limit Control: Remove cover and note temperature setting. With the burner operating, decrease this setting to the minimum point. When boiler water temperature exceeds this set point, the high limit switch will open, shutting off the power to the oil burner. Return setting to desired high limit point. Burner should restart.

2. Primary Control and Flame Sensor To Check:

- **Flame Failure:** Simulate by shutting off oil supply with hand valve while burner is on. Sixty seconds after flameout, the safety switch locks out, ignition stops, motor stops and oil valve - when used - closes. To restart, open oil supply valve and reset safety switch.

- **Ignition Failure:** With burner off, close oil supply valve and run through start-up procedure, The safety switch should lock out as in flame failure.

- **Power Failure:** Turn off main power supply switch while burner is operating. When burner stops, restore power and burner should start.

If operation is not as described as above, check wiring and controls.

PREVENTIVE MAINTENANCE of an oil fired boiler reduces operating costs. The boiler and vent pipe should be inspected for accumulation of soot or scale deposits periodically but at least once every year before the start of each heating season. When soot is present on the section walls and flueways, improper combustion will result, causing additional sooting and scaling until flueways are completely closed. To remove soot and scale from the flueways, remove top jacket panel, top clean-out plate, open burner swing door.

PERIODIC INSPECTION and tightening of the tankless heater/cover plate bolts will reduce the risk of leaks.

WARNING

- **USE ONLY NUMBER 2 FUEL OIL.**
- **DO NOT USE GASOLINE, CRANKCASE DRAININGS OR ANY OIL CONTAINING GASOLINE.**
- **DO NOT ATTEMPT TO START THE BURNER WHEN EXCESS OIL HAS ACCUMULATED, WHEN THE UNIT IS FULL OF VAPOR OR WHEN THE COMBUSTION CHAMBER IS VERY HOT.**

TYPICAL VENT SAFETY SWITCH INSTALLATION

This boiler may also be installed with a pressure switch. For side-wall vented boilers the unit uses a .35" w.c. pressure switch. It is mounted to the jacket using the screws provided and is wired to the T-T terminals on the Oil Primary for oil-fired boilers (as shown below).

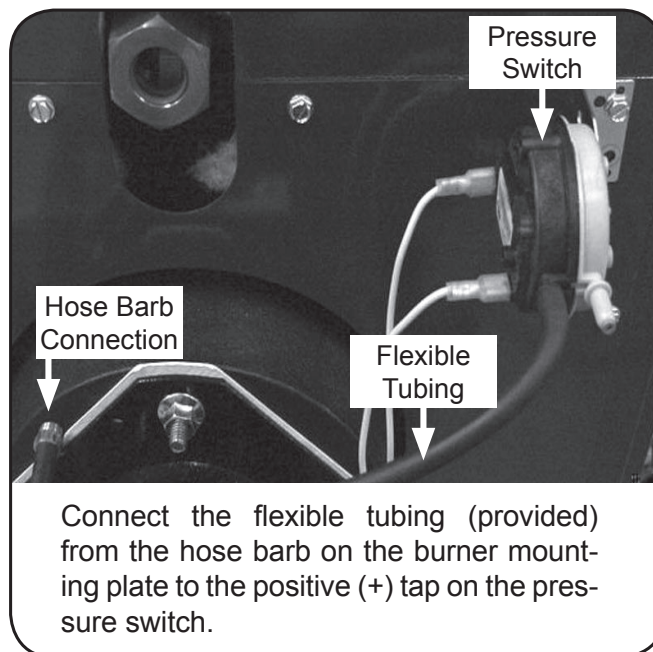
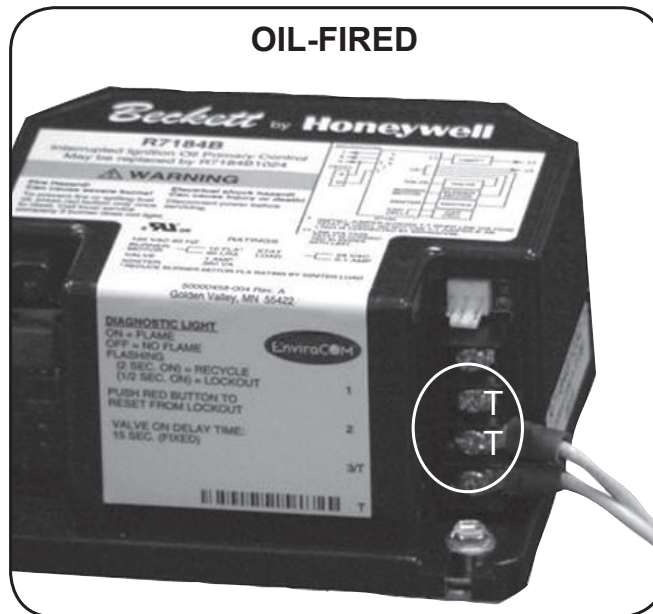

MAINTENANCE

ANNUAL SERVICE CHECK

To assure trouble-free operation, we recommend that you have the flue passages, burner, combustion chamber, burner adjustment and operation of the controls checked once a year by a competent service technician.

Before the start of each season (or whenever the system has been shut down for some time) re-check the whole system for leaks, including the boiler and vent pipe. Replace or patch any faulty boiler seals. Check the silicone rubber seals around the flue collector, between boiler sections, and around the fire door. Ensure that there are no leaks. Use RTV silicone rubber adhesive sealant (available in caulking gun tubes) rated for 400°F to replace or repair seals in locations where original seals have deteriorated.

Flue passages between boiler sections should be examined annually and cleaned if necessary. See cleaning instructions that follow.



Label all wires prior to disconnection when servicing controls. Wiring errors can cause improper and dangerous operation. Verify proper operation after servicing.

VENT PIPE

Visually inspect the entire venting system once a month for any signs of leakage or deterioration. If the vent shows any signs of leaking, replace it immediately.

RELIEF VALVE

Do not connect directly to a drain, but leave an air gap. No shut-off of any description shall be placed between the safety relief valve and the boiler, or on discharge pipes between such safety valves and the atmosphere. Installation of the safety relief valve shall conform to the ANSI/ASME Boiler and pressure Vessel Code, Section IV. The manufacturer is not responsible for any water damage.

This valve should open automatically when the system pressure exceeds the safe limits (30 pounds per square inch). Should it ever fail to open under this condition, shut down your system.

Drain it until pressure is reduced below the safe limit. Then have the valve replaced immediately. The relief valve should be tested monthly. Refer to valve manufacturer's instructions packaged with relief valve.

EXPANSION TANK

The expansion tank may become waterlogged or may receive an excess of air. Frequent automatic opening of the relief valve indicates water logging. A high boiler temperature accompanied by unusually low radiation unit temperature (and "knocking") indicates excess air in tank.

To correct either condition, close the valve between the boiler and the tank. Drain the tank until it is empty. Check all the tank plugs and fittings. Tighten as necessary. Open the valve between the boiler and tank. Water will rise to the normal height in the tank if you have an automatic fill valve (otherwise, manually refill the system).

WATER SYSTEM

If system is to remain out of service during freezing weather and does not contain antifreeze, **always drain it completely**. Water left in to freeze will crack the pipes and/or boiler.

ANTIFREEZE

Where used, antifreeze solution must be checked at least once a year in the manner recommended by the manufacturer of the antifreeze. The antifreeze includes a corrosion inhibitor that can become depleted in time, causing the solution to become corrosive. It is important that this be checked and the inhibitor be replenished or the system be refilled with fresh antifreeze solution, whichever may be required.

Antifreeze must be non-toxic, and of a type specifically intended for use in closed hydronic heating systems. Under no circumstances should automotive antifreeze be used.

TANKLESS COIL GASKET

The tankless coil gasket should be checked at least twice a year, for leakage, and replaced if necessary.

OIL BURNER MAINTENANCE

The following preventive maintenance items should be performed annually, preferably prior to the heating season.

OIL BURNER MOTOR: Add 2-3 drops of non-detergent electric motor oil to each oil cup located at the front and rear of the motor. Excessive oiling will shorten the life expectancy of the motor.

FUEL FILTER: This should be replaced so as to prevent contaminated fuel from reaching the nozzle. A partially blocked fuel filter can cause premature failure of the fuel pump unit.

FUEL PUMP UNIT: Replace pump screen and clean pump unit to maintain reliable fuel delivery to the nozzle.

IGNITION ELECTRODES: Clean and adjust as per manufacturer's recommendations, so as to maintain reliable ignition of the oil.

NOZZLE: Replace so as to maintain safe and reliable combustion efficiency.

FAN AND BLOWER HOUSING: These must be kept clean, free of dirt, lint and oil so as to maintain the proper amount of air the fuel requires to burn.

NOTE: If any component parts must be replaced, always use parts recommended by the burner manufacturer.



CAUTION

After reassembling the burner, perform complete combustion tests using combustion test instruments.

BOILER CLEANING INSTRUCTIONS

1. Shut off all electrical power to the boiler/burner and shut off fuel supply.
2. Remove the sheet metal smoke pipe from the top of the boiler. Inspect pipe and chimney for signs of corrosion and deterioration. Clean base of chimney.

3. Remove relief valve discharge pipe and top jacket panel.

4. Remove the two brass wing nuts holding the flue collector top. Remove the collector top.

5. Check the gasket on the underside of the flue collector and replace as necessary.

6. Remove the burner. Service burner per burner manufacturer's instructions.

7. Inspect the combustion chamber and fire door insulation for cracking and deterioration, replace before reassembling the boiler.

8. Remove soot from fireside surfaces by brushing diagonally through the flue passages as shown below. Care should be taken so as not to damage the combustion chamber with the flue brush.

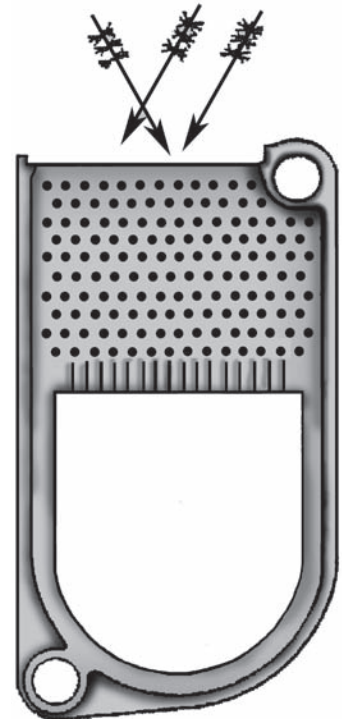

9. Reinstall the burner.

10. Reinstall the flue collector top and secure with the two brass wing nuts.

11. Reinstall the top jacket panel. Reconnect the flue pipe. Reinstall relief valve discharge pipe.

12. Reconnect the electrical and fuel supplies.

13. Fire the burner, checking for proper combustion using combustion test equipment and making adjustments as necessary.

14. Insure that all safety controls and operating controls are functioning properly.

MAINTENANCE REQUIREMENTS

Keep your boiler and the area around it clean. leave combustible material near or around it.

Never burn garbage, paper, or any material other than the specified fuel in your boiler and never Have your boiler checked each year by a qualified service technician.

TROUBLESHOOTING

YOU MAY AVOID INCONVENIENCE AND SERVICE CALLS BY CHECKING THESE POINTS BEFORE YOU CALL FOR SERVICE. HAVE YOUR SERVICE TECHNICIAN CHECK ANY PROBLEM YOU ARE UNABLE TO CORRECT.

PROBLEM	POSSIBLE CAUSE	WHAT TO DO
SYSTEM NOT HEATING OR GIVING ENOUGH HEAT	Thermostat is not set correctly.	Reset thermostat above room temperature.
	Boiler and/or burner may be dirty.	Clean all flue passages and the vent pipe. Have burner cleaned and readjusted.
	Burner may not be firing at proper rate.	Check nozzle size or orifice size if there is any doubt. Have burner adjusted.
	Burner may be short-cycling.	Short-cycling (too frequent off and on) of burner will cause sooting. If boiler and/or burner become dirty at frequent intervals, after correcting the "dirt condition" also correct the control setting (or other cause of the short-cycling). Check thermostat heat anticipator and correct setting, if necessary per instruction sheet packed with thermostat.
	No power to boiler.	Check over-current protection. Check to be sure power supply circuit is "ON."
	Controls out of adjustment.	Reset according to instructions packed with controls.
	Radiators not heating.	Open radiator vents to vent excess air. Check flow control valve (if used). It may be in closed position.
	Circulating pump not running.	Check relay operation.
	Poor electrical contact.	Check all control terminals and wire joints.
BURNER NOISY	Burner fan wheel may be dirty.	Clean fan wheel with a stiff brush and cleaning solvent. Re-adjust burner.
	Draft regulator may be stuck (where applicable).	Check to see if vane swings freely. If vane is stuck, clean.
RADIATORS NOISY	Air in system.	Open radiator vents to vent air. Check expansion tank.
RELIEF VALVE LEAKING	Dirt on seat.	Open valve manually. Allow water to run and clear valve seat.
	Water logged expansion tank.	Drain tank (<i>see instructions</i>).

PF SERIES CAST IRON PRESSURE-FIRED WET BASE HOT WATER BOILERS

IMPORTANT – READ THESE INSTRUCTIONS BEFORE ORDERING

All parts listed on the following pages may be ordered through your nearest supplier. When ordering parts, first obtain the model number from the data plate on your boiler, then determine the part number and description of each part from the following illustrations.

INCLUDED IN THIS SECTION:

- Boiler Parts
- Indoor Jacket Parts
- Weatherproof Jacket Parts
- Direct Exhaust System Parts
- Boiler Controls and Piping



BOILER PARTS

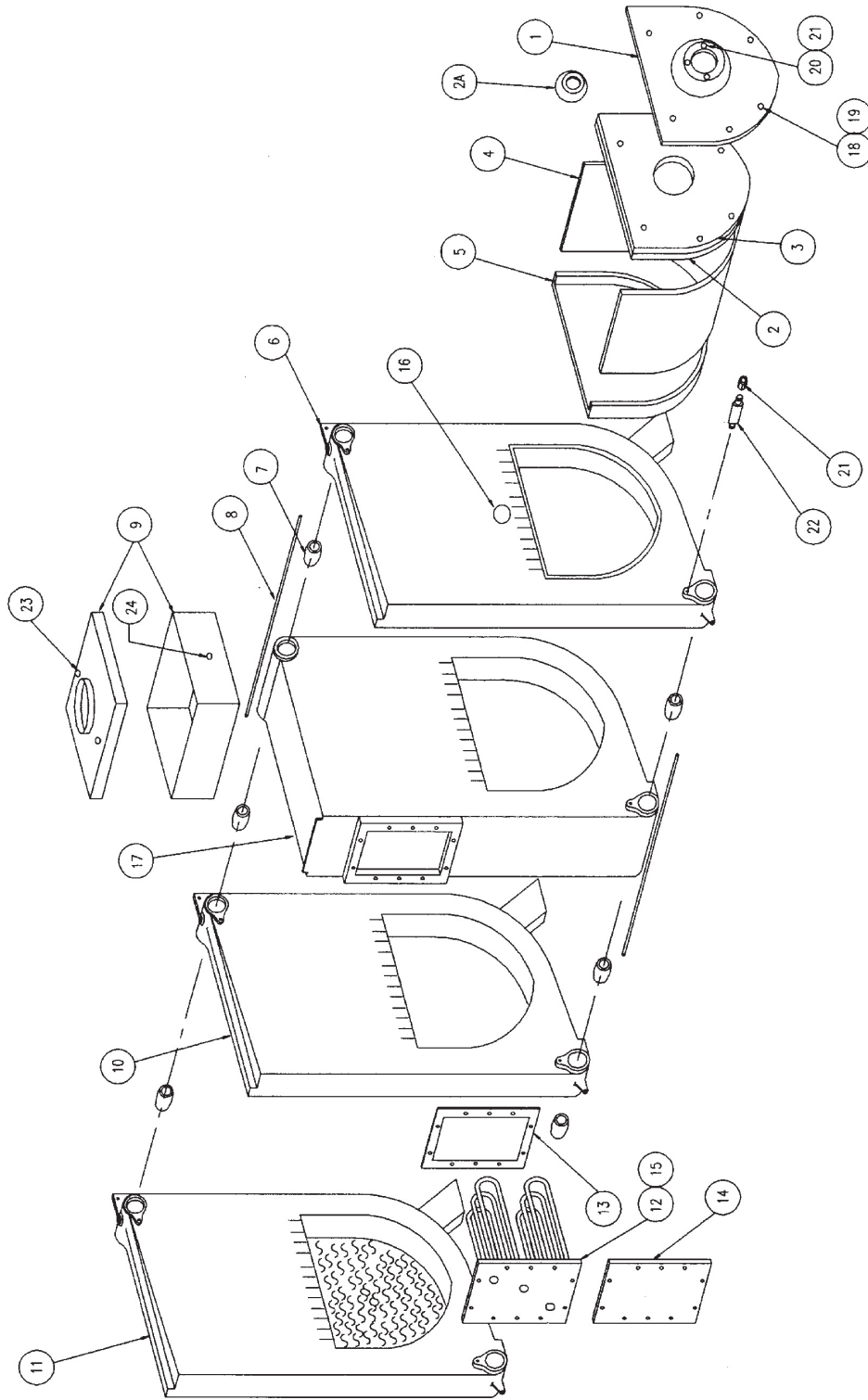

BOILER PARTS - WITH TANKLESS COIL

ITEM	DESCRIPTION	MODEL 3T	MODEL 4T	MODEL 5T	MODEL 6T	MODELS 7TT, 8T
1	Fire Door	41982001	41982002	41982002	41982002	41982002
2	Front Chamber	14630021	14630021	14630021	14630021	14630021
2A	Cone Chamber	-	-	-	-	-
3	Front Plate	14630022	14630022	14630022	14630022	14630022
4	Durablanket	14630031	14630031	14630031	14630031	14630031
5	Rear Chamber	14630023	14630023	14630023	14630023	14630023
6	Front Section	41900001	41900001	41900001	41900001	41900001
7	Push Nipples	43300976	43300976	43300976	43300976	43300976
8	Tie Rods	HW011.01	14605003	14605054	14605005	14605009
9	Flue Collector	42582121	42582122	42582123	42582124	42582125
10	Middle Section	-	41900002	41900002	41900002	41900002
11	Back Section	41900003	41900003	41900003	41900003	41900003
12A	Tankless Coil - Single Pass	14627023	14627023	14627023	14627023	14627023
#	Tankless Coil Kit - Single Pass (Includes 12A, 13 and 15)	43382255	43382255	43382255	43382255	43382255
12B	Tankless Coil - Two Pass	14627022	14627022	14627022	14627022	14627022
#	Tankless Coil Kit - Two Pass (Includes 12A, 13 and 15)	43382259	43382259	43382259	43382259	43382259
13	Tankless Coil Gasket	14693065	14693065	14693065	14693065	14693065
14	Blank Coil Plate	14619001	14619001	14619001	14619001	14619001
15A	3/8" - 16 x 1-1/2" SS Stud (10 req'd)	14695113	14695113	14695113	14695113	14695113
15B	Nut Hex Serrated 3/8"-16 S.S.	1330008	1330008	1330008	1330008	1330008
16	Sight Glass Assembly	43382251	43382251	43382251	43382251	43382251
17	Coil Section	41900004	41900004	41900004	41900004	41900004
18	5/16" x 1-5/8" Stud (Firedoor - 6 req'd)	HW06701	HW06701	HW06701	HW06701	HW06701
19	5/16" Hex Nut (Firedoor - 6 req'd)	1330007	1330007	1330007	1330007	1330007
20	5/16" x 1-3/8" Stud (Burner - 3 req'd)	HW07001	HW07001	HW07001	HW07001	HW07001
21	5/16" Acron Nut (7 req'd)	14695042	14695042	14695042	14695042	14695042
22	Jacket Standoff (4 req'd)	14685103	14685103	14685103	14685103	14685103
23	#8 - 32 Brass Wing Nuts (2 req'd)	13704007	13704007	13704007	13704007	13704007
24	#14 - 1" Sheet Metal Screw	14695109	14695109	14695109	14695109	14695109
#	Combustion Chamber Replacement Kit (Includes Items 2 or 2A, 3, 4, and 5)	43382262	43382263	43382264	43382265	43382266

BOILER PARTS - WITHOUT TANKLESS COIL

ITEM	DESCRIPTION	MODEL 3	MODEL 4	MODEL 5	MODEL 7	MODEL 9
1	Fire Door	41982002	41982002	41982002	41982002	41982002
2	Front Chamber	-	14630021	14630021	14630021	14630021
2A	Cone Chamber	14630025	-	-	-	-
3	Front Plate	14630024	14630022	14630022	14630022	14630022
4	Durablanket	14630031	14630031	14630031	14630031	14630031
5	Rear Chamber	14630023	14630023	14630023	14630023	14630023
6	Front Section	14600001	41900001	41900001	41900001	41900001
7	Push Nipples	43300976	43300976	43300976	43300976	43300976
8	Tie Rods	14605044	HW011.01	14605003	14605005	14605009
9	Flue Collector	42582131	42582121	42582122	42582124	42582125
10	Middle Section	41900002	41900002	41900002	41900002	41900002
11	Back Section	41900003	41900003	41900003	41900003	41900003
15A	3/8" - 16 x 1-1/2" SS Stud (10 req'd)	-	-	-	-	-
15B	Nut Hex Serrated 3/8"-16 S.S.	-	-	-	-	-
16	Sight Glass Assembly	43382251	43382251	43382251	43382251	43382251
17	Coil Section	-	-	-	-	-
18	5/16" x 1-5/8" Stud (Firedoor - 6 req'd)	HW06701	HW06701	HW06701	HW06701	HW06701
19	5/16" Hex Nut (Firedoor - 6 req'd)	1330007	1330007	1330007	1330007	1330007
20	5/16" x 1-3/8" Stud (Burner - 3 req'd)	HW07001	HW07001	HW07001	HW07001	HW07001
21	5/16" Acron Nut (7 req'd)	14695042	14695042	14695042	14695042	14695042
22	Jacket Standoff (4 req'd)	14685103	14685103	14685103	14685103	14685103
23	#8 - 32 Brass Wing Nuts (2 req'd)	13704007	13704007	13704007	13704007	13704007
24	#14 - 1" Sheet Metal Screw	14695109	14695109	14695109	14695109	14695109
#	Combustion Chamber Replacement Kit (Includes Items 2 or 2A, 3, 4, and 5)	43382261	43382262	43382263	43382265	43382266

NOTE: Parts 12-14 not applicable to Models 3, 4, 5, 7, and 9. See Models 3T, 4T, 5T, 6T, 7TT, and 8T (below).

INDOOR JACKET PARTS

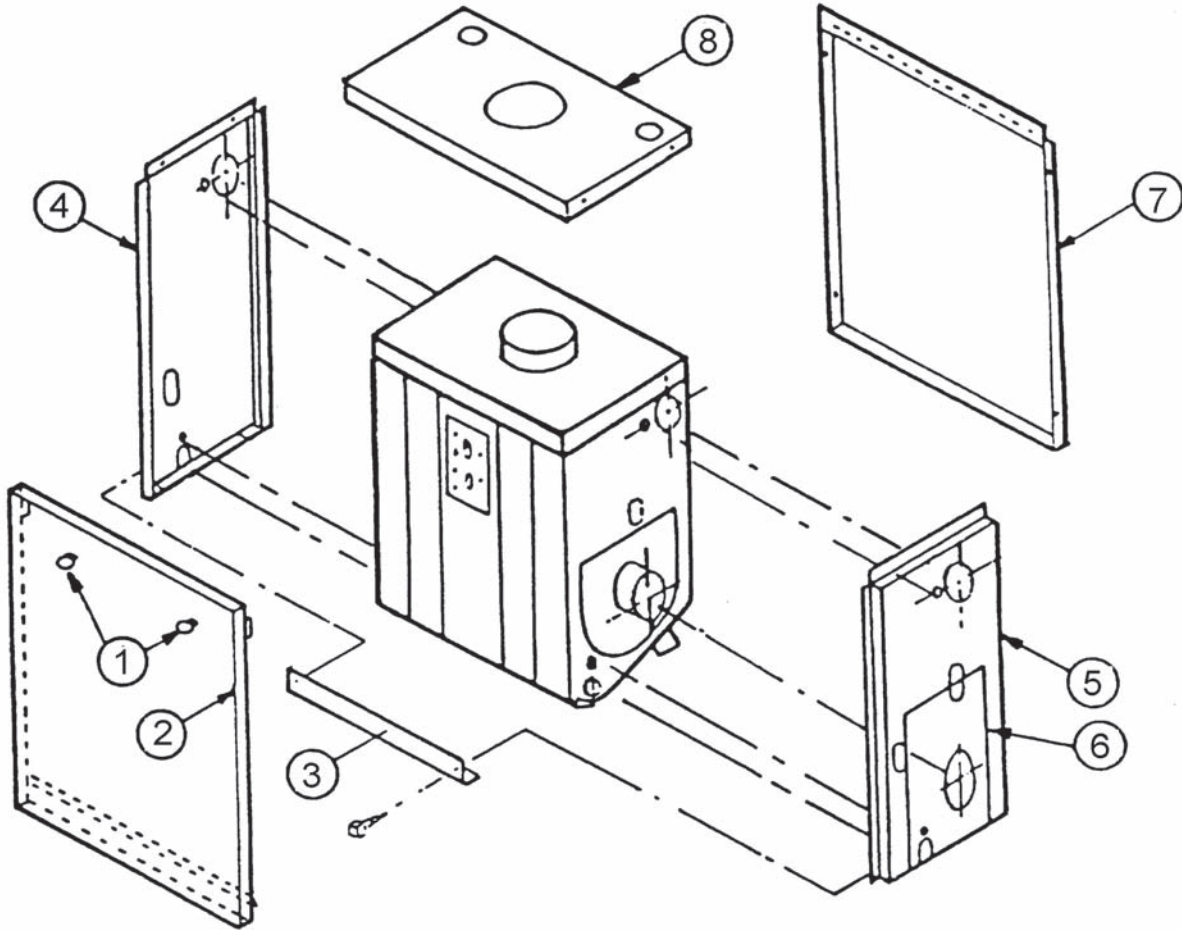

ITEM	DESCRIPTION	MODEL 3	MODEL 3T, 4	MODEL 4T, 5	MODEL 5T	MODEL 6T, 7	MODEL 7TT, 8T, 9
1	KNOB SET	13702153	13702153	13702153	13702153	13702153	13702153
2	JACKET DOOR	42582049AC	42582044AC	42582045AC	42582046AC	42582047AC	42582048AC
3	TIE BAR	42500653	42500653	42500653	42500653	42500653	42500653
4	LEFT SIDE JACKET PANEL	42582030AC	42582030AC	42582030AC	42582030AC	42582030AC	42582030AC
5	RIGHT SIDE JACKET PANEL	42582028AC	42582031AC	42582031AC	42582031AC	42582031AC	42582031AC
6	RIGHT SIDE COVER PLATE	42582029AC	42582032AC	42582032AC	42582032AC	42582032AC	42582032AC
7	BACK PANEL	42582038AC	42582033AC	42582034AC	42582035AC	42582036AC	42582037AC
8	TOP PANEL	42582065BA	42582060BA	42582061BA	42582062BA	42582063BA	42582064BA
-	COMPLETE JACKET	742001003BA	742001004BA	742001005BA	742001006BA	742001007BA	742001009BA

WEATHERPROOF JACKET PARTS

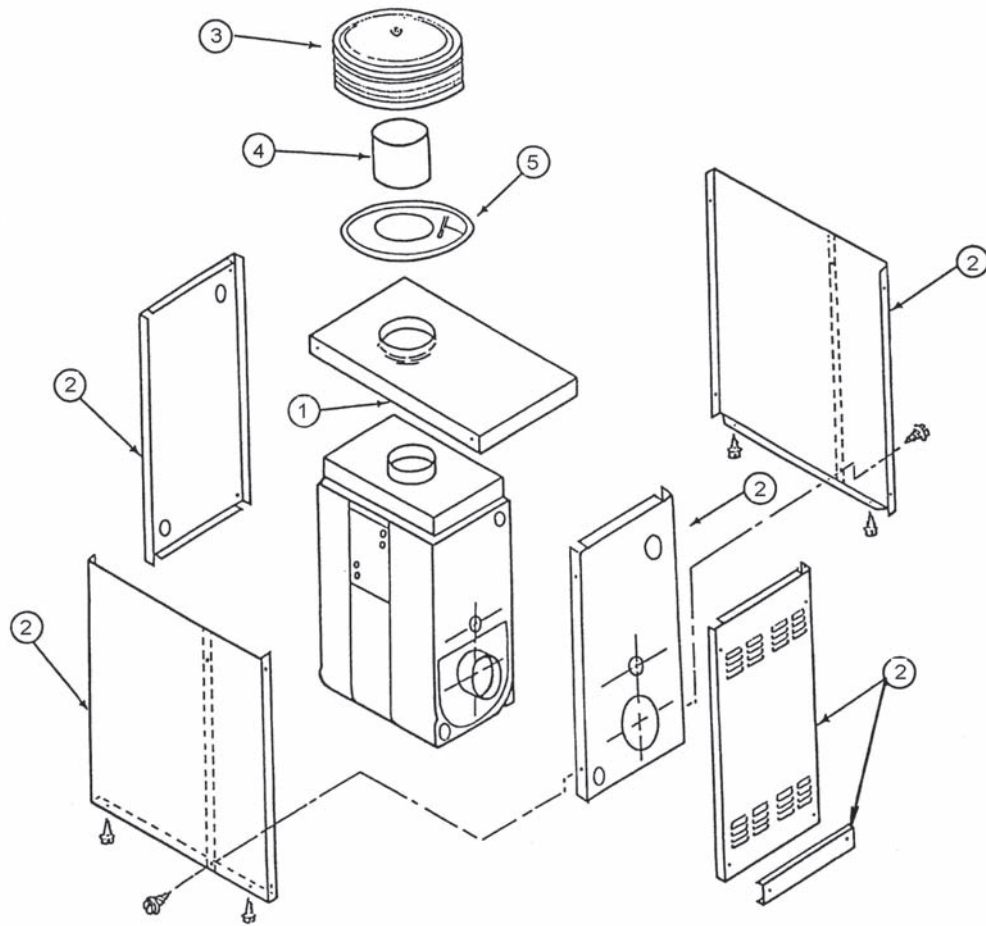

ITEM	DESCRIPTION	MODELS 3TW, 4W	MODELS 6TW, 7W	MODELS 7TTW, 8TW, 9W
1	Top Panel	14630411	14630412	14630413
2	Jacket	14630402	14630403	14630404
3	Weather Shield	14630421	14630424	14630427
4	Flue Pipe	14630423	14630426	14630429
5	Collar	14630422	14630425	14630428

DIRECT EXHAUST SYSTEM PARTS

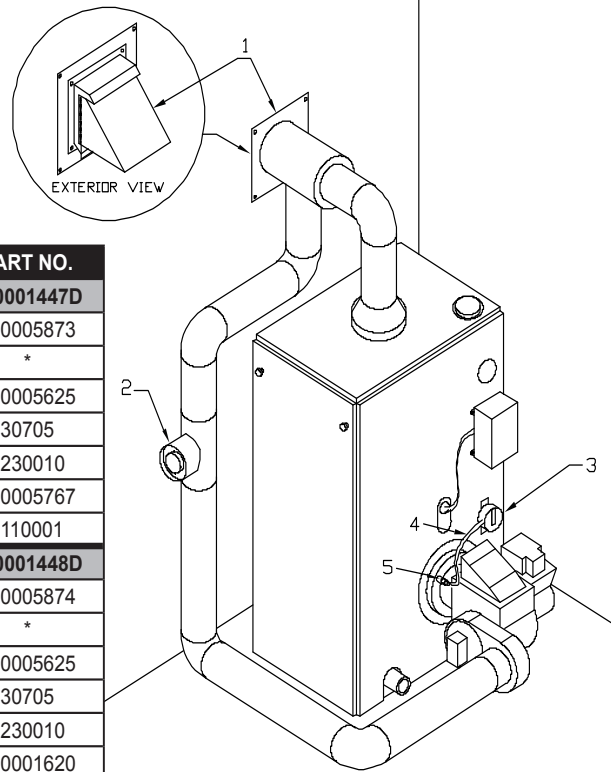

ITEM	DESCRIPTION	PART NO.
KIT,EV/FVDS-4AL,DIR EXH CTN LESS BURNER		550001447D
1	4" VENT EXHAUST HOOD	240005873
2	VACUUM RELIEF DRAFT REGULATOR ASSY	*
3	PRESSURE SWITCH	240005625
4	VITON TUBING	30705
5	BRASS BARB	1230010
**	PRESS SWITCH WIRE HARNESS	240005767
**	ROTOR CLAMP	1110001
KIT,EV/FDVS-6AL/SL,DIR EXH CTN LESS BURNER		550001448D
1	4" VENT EXHAUST HOOD	240005874
2	VACUUM RELIEF DRAFT REGULATOR ASSY	*
3	PRESSURE SWITCH	240005625
4	VITON TUBING	30705
5	BRASS BARB	1230010
**	8 SEC 1.90 GPH DERATE KIT	550001620
**	PRESS SWITCH WIRE HARNESS	240005767
**	ROTOR CLAMP	1110001
KIT,EV/FDVS-6SW,DIR EXH CTN LESS W/ CF375 BURNER W/BOOT		550001449D
1	4" VENT EXHAUST HOOD	240005874
2	VACUUM RELIEF DRAFT REGULATOR ASSY	*
3	PRESSURE SWITCH	240005625
4	VITON TUBING	30705
5	BRASS BARB	1230010
**	BECKETT BURNER CF375 W/ SIDE WALL BOOT	240006433
**	PRESS SWITCH WIRE HARNESS	240005767
**	ROTOR CLAMP	1110001
KIT,EV/FDVS-4AW,DIR EXH CTN LESS W/ AFG BURNER W/BOOT		550001450D
1	4" VENT EXHAUST HOOD	240005873
2	VACUUM RELIEF DRAFT REGULATOR ASSY	*
3	PRESSURE SWITCH	240005625
4	VITON TUBING	30705
5	BRASS BARB	1230010
**	BECKETT BURNER AFG W/ SIDE WALL BOOT	14619202
**	PRESS SWITCH WIRE HARNESS	240005767
**	ROTOR CLAMP	1110001
KIT,EV/FDVS-6AW,DIR EXH CTN LESS W/ AFG BURNER W/BOOT		550001451D
1	4" VENT EXHAUST HOOD	240005874
2	VACUUM RELIEF DRAFT REGULATOR ASSY	*
3	PRESSURE SWITCH	240005625
4	VITON TUBING	30705
5	BRASS BARB	1230010
**	BECKETT BURNER AFG W/ SIDE WALL BOOT	14619202
**	PRESS SWITCH WIRE HARNESS	240005767
**	ROTOR CLAMP	1110001

* Item #2 Included With Item #1

** Not Shown

BOILER CONTROLS AND PIPING

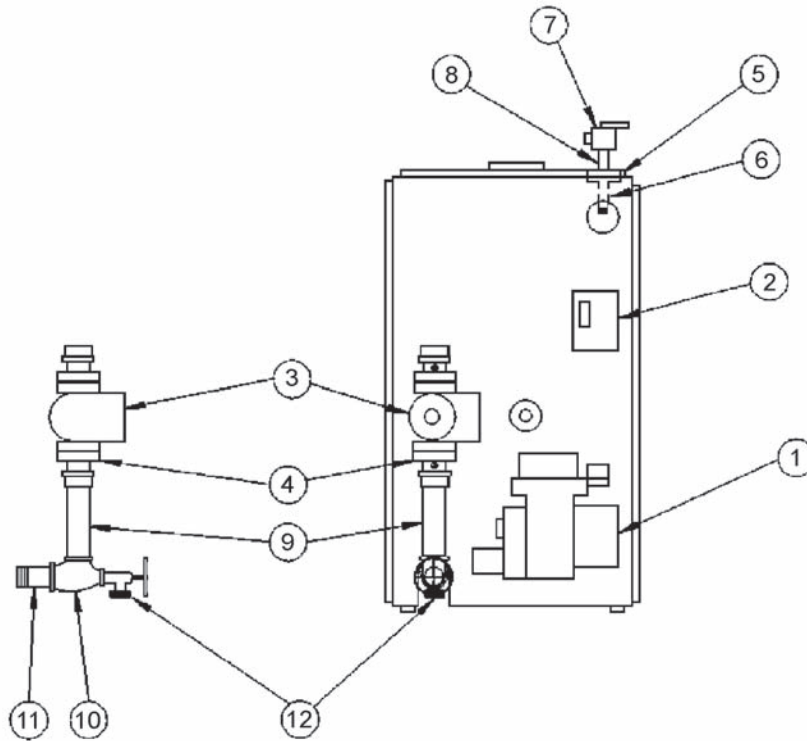

ITEM	DESCRIPTION	PART NO.
1	Beckett AFG Standard Oil Burner (2.00 gph or less)	14619201
-	Beckett CF375 Standard Oil Burner (2.00 gph or more)	240006445
-	Riello 40 F5 Standard Oil Burner (0.90 to 1.50 gph)	1050006
-	Riello 40 F10 Standard Oil Burner (1.60 to 3.00 gph)	14619011
-	Beckett AFG Direct Vent Oil Burner (2.00 gph or less)	14619202
-	Beckett CF375 Direct Vent Oil Burner (2.00 gph or less)	240006433
*	Beckett CF56KY ATC Head Convert Kit	550001620
2	L8151A1054 Triple Acting Aquastat	14662201
3	Taco 007 Circulator (except Models 7TT, 8T, 9)	CI-001.03
-	Taco 0012 Circulator (Models 7TT, 8T, 9)	14626062
4	1 1/4" Taco Isolation Valves	14626043
-	1 1/2" Flanges	14626063
5	Temperature Pressure Gauge	1260006
6	3/4" x 1/4" Bushing	1060002
7	3/4" ASME Relief Valve	14622011
8	3/4" x 4 1/2" Nipple	14607202
9	1 1/4" x 10" Nipple (except Models 7TT, 8T, 9)	14607012
-	1 1/2" x 12" Nipple (Models 7TT, 8T, 9)	14607206
10	1 1/4" x 3/4" x 1 1/4" Tee (except Models 7TT, 8T, 9)	1510001
-	1 1/2" x 3/4" x 1 1/2" Tee (Models 7TT, 8T, 9)	1510002
11	1 1/4" x 2 1/2" Nipple (except Models 7TT, 8T, 9)	14607044
-	1 1/2" x 2 1/2" Nipple (Models 7TT, 8T, 9)	1310005
12	3/4" Boiler Drain Valve	14622000
*	1 1/2" x 1 1/4" Bushing (except Models 7TT, 8T, 9)	14693204
*	Immersion Well for Aquastat	14630020
*	1 1/2" x 3/4" Bushings	14693201
*	1 1/2" Sq. Hd. Plugs	1395005
*	400°F Black Silicone Rubber Adhesive Sealant (10.3 oz. cartridge)	14606020
*	500°F Red Silicone Rubber Adhesive Sealant (10.3 oz. cartridge)	1460001

* Not Shown

